



TECHNICAL SERVICE BULLETIN

2021-2023 Mustang Mach-E - Various Driver Assistance System Warning Messages - DTCs C1001:31, U3000:89, And/Or U3000:49 Stored In The IPMA

25-2156

25 April 2025

This bulletin supersedes 23-2155. Reason for update: update the Service Procedure, Parts List and change the labor operation from actual time to actual time with a cap.

Model:

Ford 2021-2023 Mustang Mach-E

Markets: North American markets only

Issue: Some of the vehicles listed in the Model statement above may exhibit DTCs C1001:31, U3000:89, and/or U3000:49 stored in the IPMA and at least one of the following conditions:

- "Front Camera Fault Service Required" message
- Pre-collision Assist inoperative
- Adaptive cruise control inoperative
- Front windshield camera alignment routine fails to complete

This may be due to a connection issue between the IPMA Camera and the IPMA.

Action: For vehicles that meet all of the criteria in the Issue and Model statements, follow the Service Procedure to repair the connection between the IPMA camera and IPMA.

Parts

Service Part Number	Claim Quantity	Package Order Quantity	Description
164-R9343	As Needed	As Needed	3M™ Film Tape 9343
Obtain Locally	As Needed	As Needed	Zip Ties

Parts - Parts To Inspect And Replace Only If Necessary

Service Part Number	Claim Quantity	Package Order Quantity	Description
LJ8Z-14F662-B	Only If Necessary	Only If Necessary	A-Pillar to IPMA Coaxial Cable (Built With Minor Feature Code HKLAG, HKLAH, And/Or J3QAD)
LJ8Z-14D202-W	Only If Necessary	Only If Necessary	A-Pillar to IPMA Coaxial Cable (Built With Minor Feature Code HKLAF And/Or J3QAA)
LJ8Z-14D202-U	Only If Necessary	Only If Necessary	Image Processing Module A (IPMA) Camera to A-Pillar Coaxial Cable
ML3Z-19H406-B	Only If Necessary	Only If Necessary	Image Processing Module A (IPMA) Camera
19H405	Only If Necessary	Only If Necessary	Image Processing Module A (IPMA) - Refer To The Parts Catalog For The VIN Specific Application

Service part numbers and "number in package" quantity may change after publication, thus also affecting the "package order quantity". Refer to the parts catalog for the latest information.

Claim Quantity refers to the total number of individual pieces required to repair the vehicle.

Package Order Quantity refers to the amount of the service part number package(s) required to repair the vehicle.

Number In Package refers to the number of individual pieces included in a service part number package.

As Needed indicates the part is necessary but amount of the part may vary and/or is not a whole number. Parts can be billed out as non-whole numbers, including less than 1.

Only If Necessary indicates the part is not mandatory. Refer to the Service Procedure to determine the inspection/inclusion criteria.

Warranty Status: Eligible under provisions of New Vehicle Limited Warranty (NVLW)/Service Part Warranty (SPW)/Service Part New Vehicle (SPNV)/Extended Service Plan (ESP) coverage. Limits/policies/prior approvals are not altered by a TSB. NVLW/SPW/SPNV/ESP coverage limits are determined by the identified causal part and verified using the OASIS part coverage tool.

Labor Times

Description	Operation No.	Time
2021-2023 Mustang Mach-E: Retrieve DTCs Inspect And Repair Following The Service Procedure (Do Not Use With Any Other Labor Operations)	MT252156	Actual Time Up To 6.7 Hrs.

Repair/Claim Coding

Causal Part:	14D202
Condition Code:	b4

Service Procedure

1. Check the IPMA for software updates using the latest software level of the FDRS scan tool. Is there a software update available for the IPMA?
 - (1). Yes - download and run the "IPMA – Image Processing Module A (IPMA) Software Update" app. Proceed to Step 2.
 - (2). No - proceed to Step 3.
2. Did the software update correct the condition?
 - (1). Yes - repair is complete.
 - (2). No - proceed to Step 3.
3. Are DTCs C1001:31 and/or U3000:89 stored in the IPMA or were recently stored in the vehicle's 60-Day VHA/DTC History? The vehicle's 60-Day VHA/DTC History (if applicable) can be found in the PTS > Connected Vehicle > Connected Vehicle Home.
 - (1). Yes - inspect the coaxial cables between the IPMA and the IPMA camera for loose connections. Perform wiggle test to check C900 and C9128 connectors for loose connections. If no loose connections are present, proceed to Step 4. If loose connections are present, reconnect and proceed to Step 5.
 - (2). No - proceed to Step 29.
4. Power the vehicle on and wait 30 seconds. Clear and retrieve DTCs. Are DTCs C1001:31 and/or U3000:89 present in the IPMA?
 - (1). Yes - proceed to Step 6.
 - (2). No - the issue is intermittent. Replace both sections of coaxial cable running from the IPMA Camera to the IPMA following Steps 6-17 and Steps 19-26, then proceeding to Step 27.
5. Power the vehicle on and wait 30 seconds. Clear and retrieve DTCs. Are DTCs C1001:31 and/or U3000:89 present in the IPMA?
 - (1). Yes – proceed to Step 6.
 - (2). No – proceed to Step 29.
6. Replace the coaxial cable running from the IPMA Camera to the A-Pillar by overlaying the new coaxial cable next to the existing coaxial cable and cutting off the existing coaxial cable connectors. To do so, begin by removing the left A-Pillar Trim Panel. Refer to WSM, Section 501-05 Interior Trim and Ornamentation, Removal and Installation, A-Pillar Trim Panel.
7. Disconnect the left headliner wiring harness found in A-Pillar. (Figure 1)

Figure 1

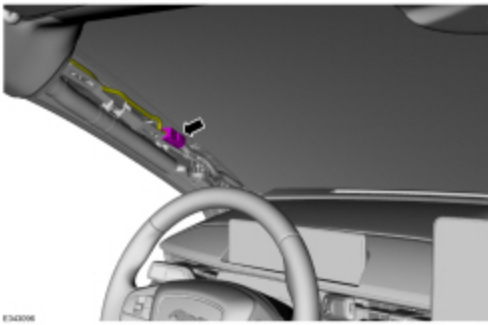

E34308

8. Disconnect left rear washer hose. (Figure 2) Refer to WSM, Section 501-16 Wipers and Washers, General Procedures, Washer Hose Coupling.

Figure 2

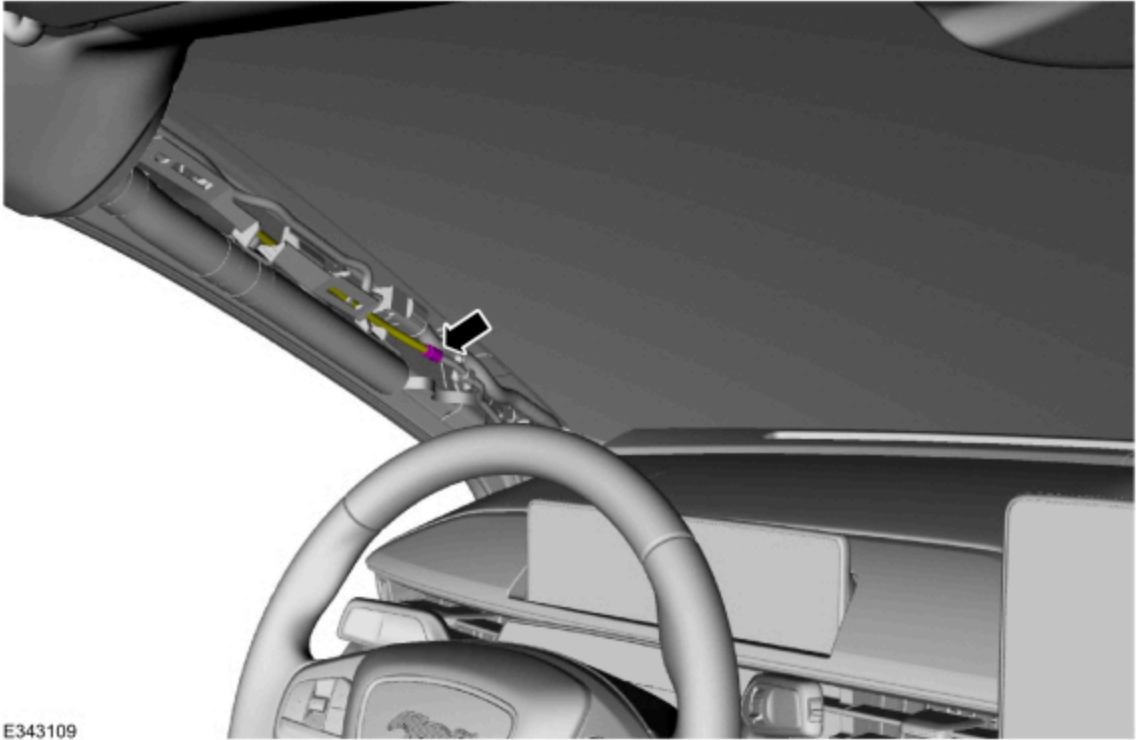

E343109

9. Remove the sun visors on both sides. (Figure 3)

Figure 3

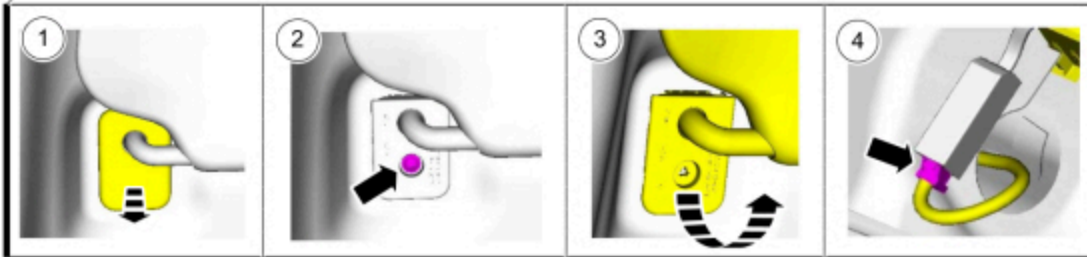

E343111

- (1). Position the sun visor screw cover aside.
- (2). Remove the sun visor screw.
- (3). Rotate the sun visor downward.
- (4). Disconnect the sun visor electrical connector.

10. Remove the sun visor clips on both sides. (Figure 4) On both sides, remove the screw and the sun visor clip.

Figure 4

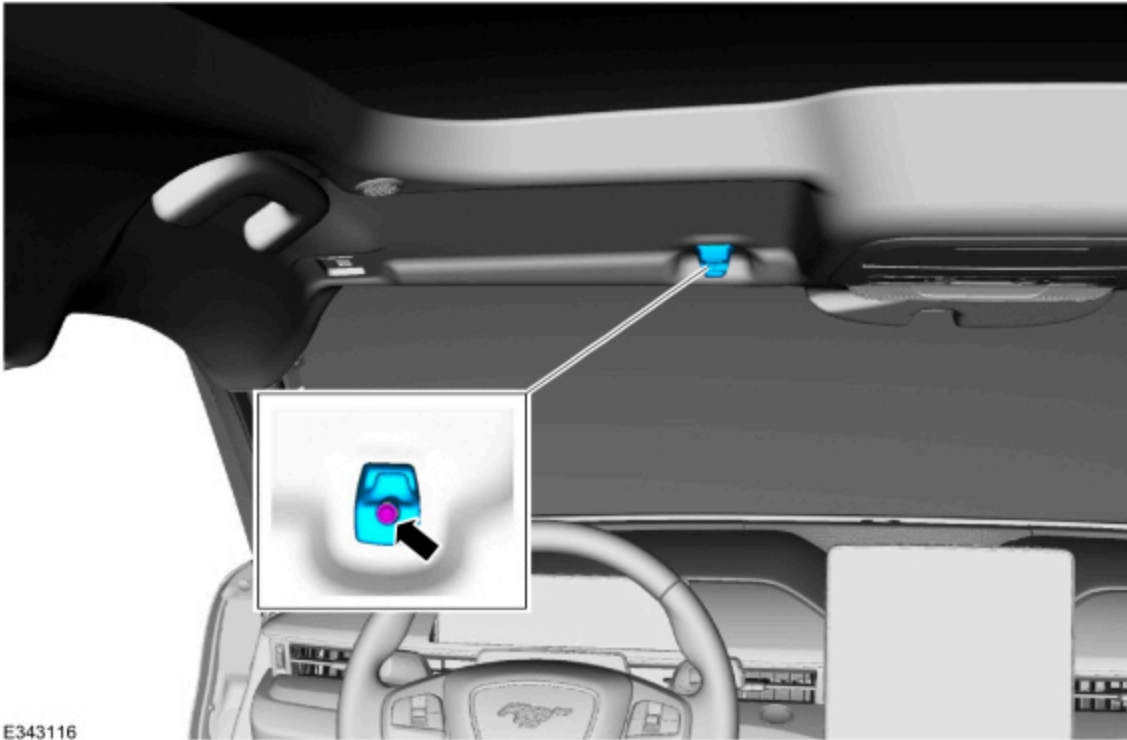

11. Remove the rear view mirror cover by releasing the clips holding the rear view mirror cover in place. (Figure 5)
Figure 5

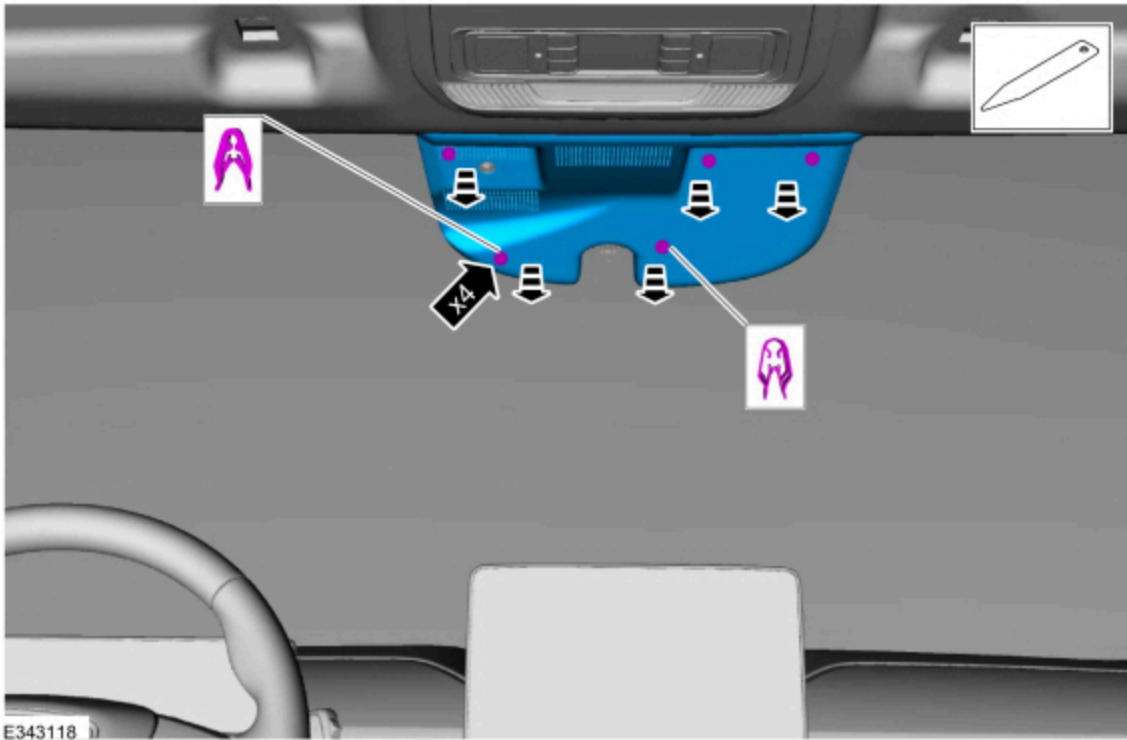

12. Disconnect C9128 connector going to the IPMA camera from the headliner.
13. Remove the front assist handles on both sides. (Figure 6)

Figure 6

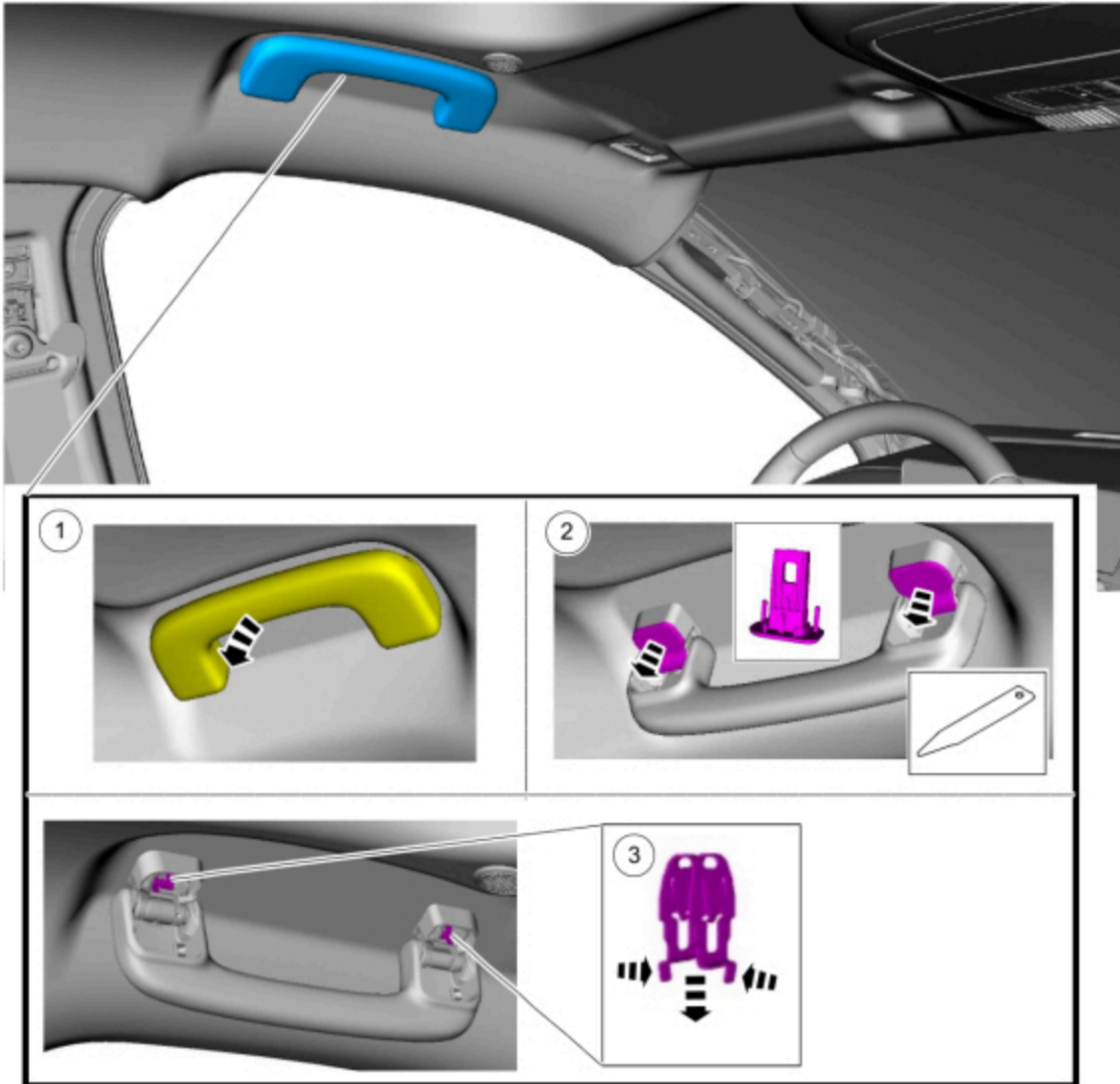

E343120

- (1). Position the front assist handle down.
- (2). Remove the front assist handle retainers.
- (3). Remove the front assist handle clips.

14. Tuck the replacement coaxial cable into the headliner behind the headliner harness and use 3M™ film tape to overlay the new coaxial cable next to the existing coaxial cable. (Figure 7) Use 3M™ film tape (not zip ties) to overlay the cable in the headliner and A-pillar, as using zip ties with sharp cuts near the side curtain airbag may impede the airbag's performance once installed. (Figure 8)

Figure 7

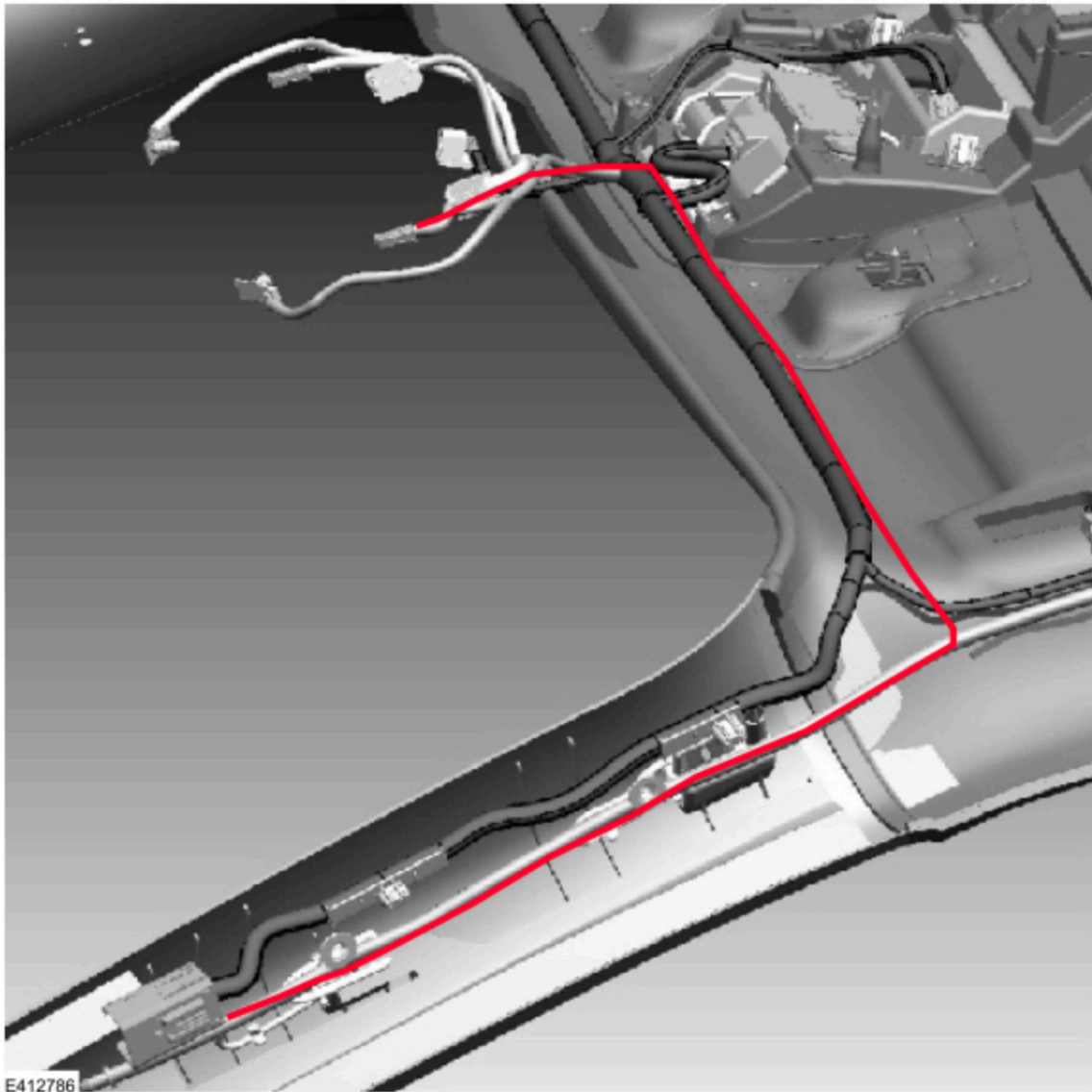

E412786

Figure 8

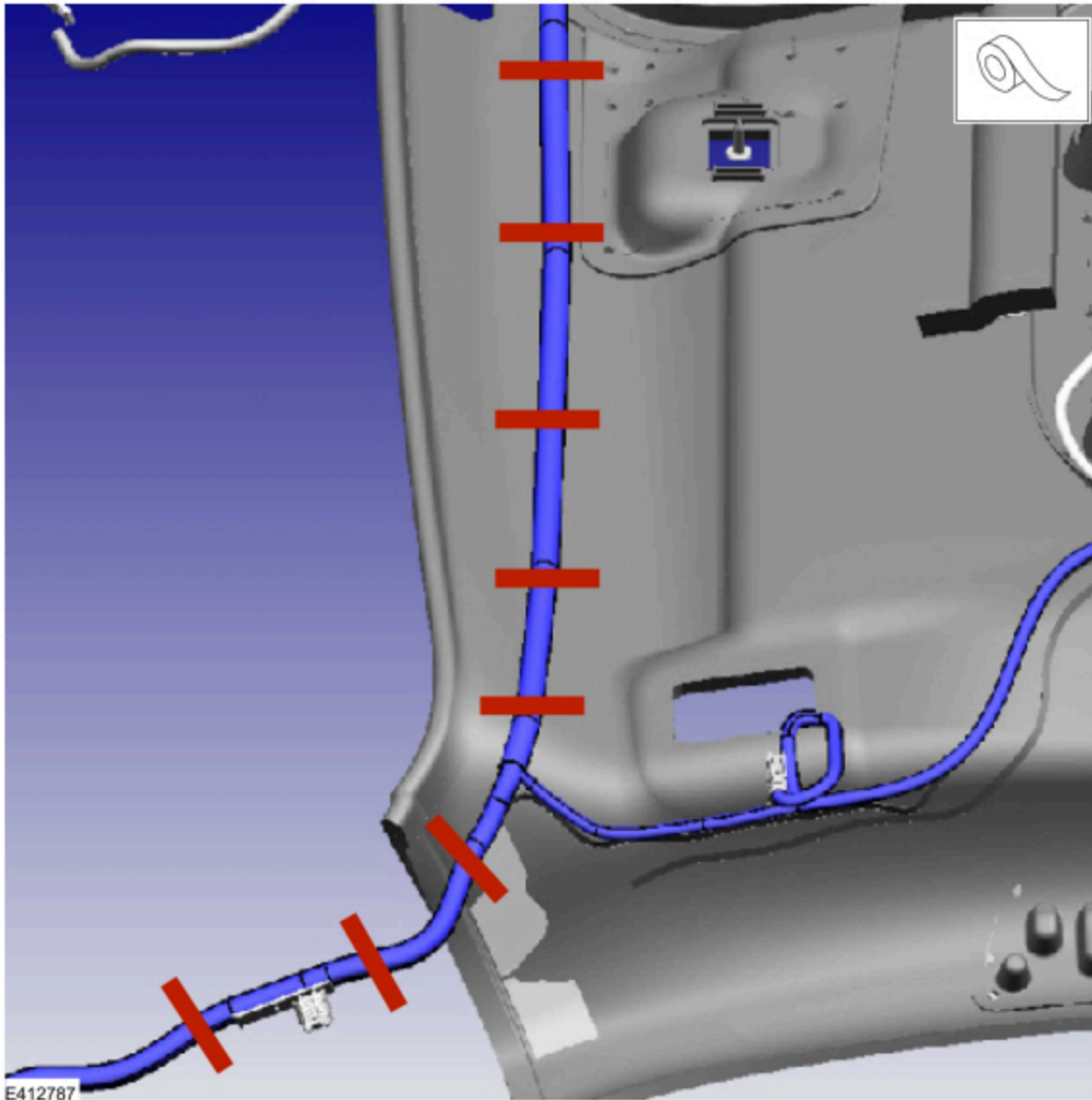

NOTE: Be sure to avoid kinking or routing the cable in such a way that it bends greater than 90 degrees over 30 mm (1.2 in), as sharp bends could damage the cable. Press the 3M™ film tape firmly to the headliner to make sure the tape adheres adequately to the headliner.

15. On the male side of the headliner wiring harness electrical connector (C900), remove the existing coaxial cable pin from the connector, and install the coaxial pin from the newly installed coaxial cable. Refer to Wiring Diagram, Connector Views, C900. (Figure 9)

Figure 9

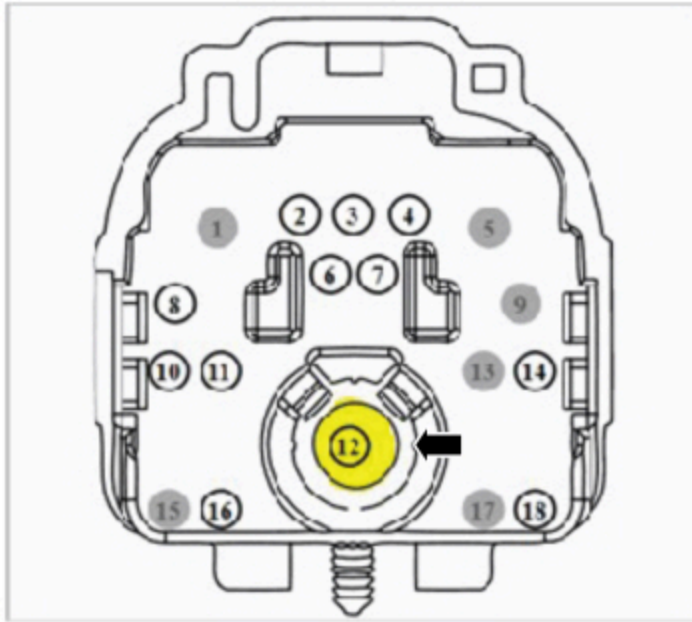

E412788

16. Reattach headliner to the roof using the headliner magnets and install new C9128 connector to the IPMA Camera and reconnect the headliner wiring harness electrical connector. Refer to Figures 10-11. Cut off the existing coaxial cable connectors to ensure the original cable is not used again.

Figure 10

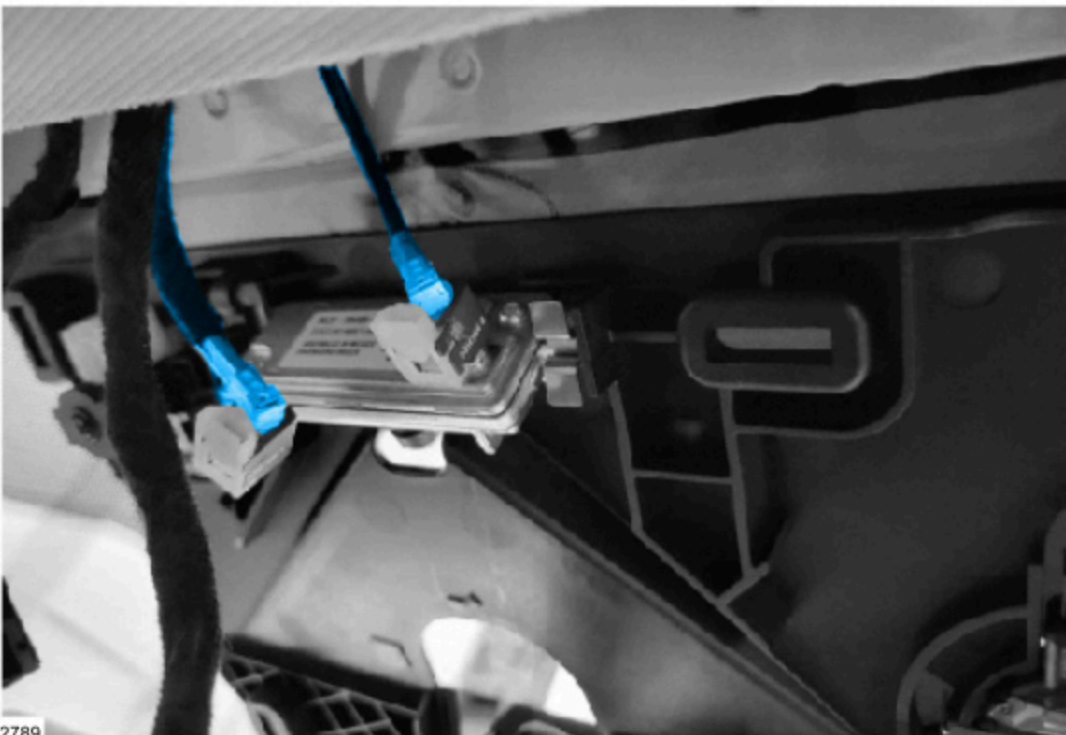

E412789

Figure 11



E412790

17. Install the newly overlaid harness in A-pillar back onto the A-pillar mounting bracket, above the fasteners that hold the bracket in place. (Figure 12)

Figure 12

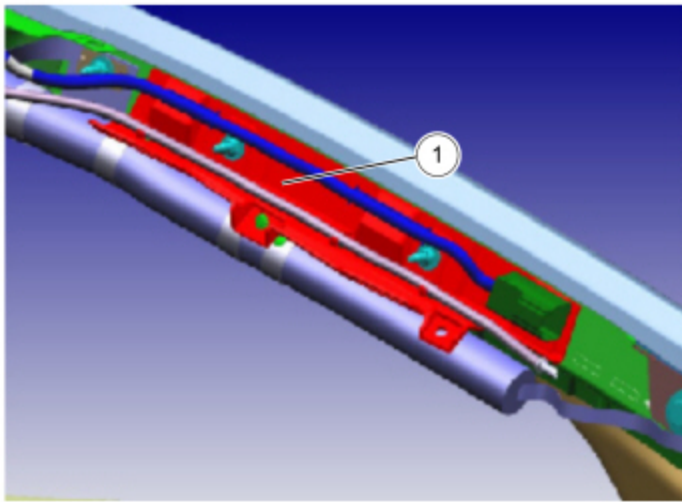

E412791

NOTE: The headliner harness must be correctly installed back on to the bracket to avoid impeding the side curtain airbag.

18. Power the vehicle on and wait 30 seconds. Clear and retrieve DTCs. Is C1001:31 and/or U3000:89 present in the IPMA?

(1). Yes – proceed to Step 19 to replace the coaxial cable running from A-Pillar to IPMA by overlaying the new coaxial cable next to the existing coaxial cable and cutting off the existing coaxial cable connectors.

(2). No - proceed to Step 29.

19. Remove the left A-Pillar trim panel if not already removed from Step 6. Refer to WSM, Section 501-05 Interior Trim and Ornamentation, Removal and Installation, A-Pillar Trim Panel.

20. On left side, disconnect headliner wiring harness electrical connector (C900). (Figure 1)

21. Remove the left B-Pillar trim panel. Refer to WSM, Section 501-05 Interior Trim and Ornamentation, Removal and Installation, B-Pillar Trim Panel.

22. Remove the left loadspace trim panel. Refer to WSM, Section 501-05 Interior Trim and Ornamentation, Removal and Installation, Loadspace Trim Panel.

23. Remove left side body harness scuff plates located under Front Scuff Plate Trim Panel Rear Scuff Plate Trim Panel. (Figures 13-14)

Figure 13



E412792

Figure 14



E412793

24. Is the vehicle equipped with minor feature codes HKLAG, HKLAH, and/or J3QAD? To confirm a vehicle is built with any of these minor feature codes, review the build information by double-clicking the VIN in the upper left corner in PTS.

(1). Yes - the replacement coaxial cable comes with an additional jumper that goes to a C2563 connector for the APIM. For these vehicles, also remove the driver side floor console front trim panel, passenger side footwell trim panel, and passenger side floor console front trim panel. Refer to WSM, Section 501-12 Instrument Panel and Console, Removal and Installation.

(2). No - proceed to Step 25.

25. Using small zip ties, overlay the new coaxial cable next to the existing 14335 harness. (Figures 15–18) If extra cable length is present when routing the new coaxial cable, loop and stow the excess length. (Figure 18)

Figure 15

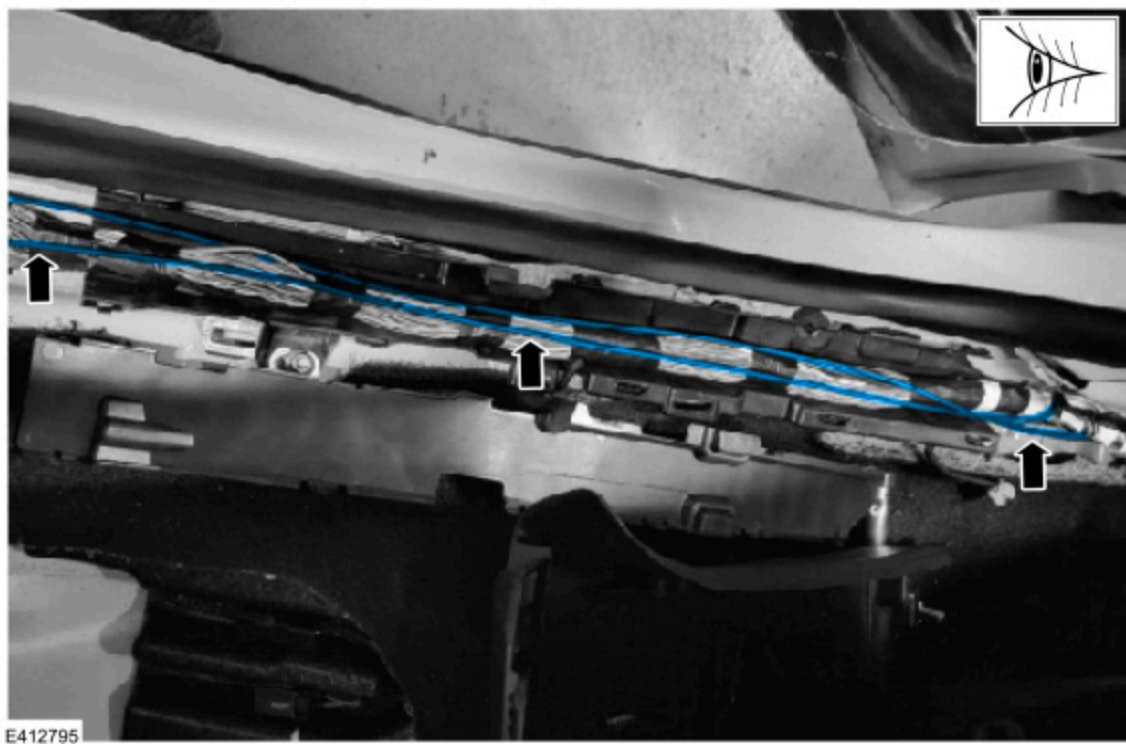

Figure 16

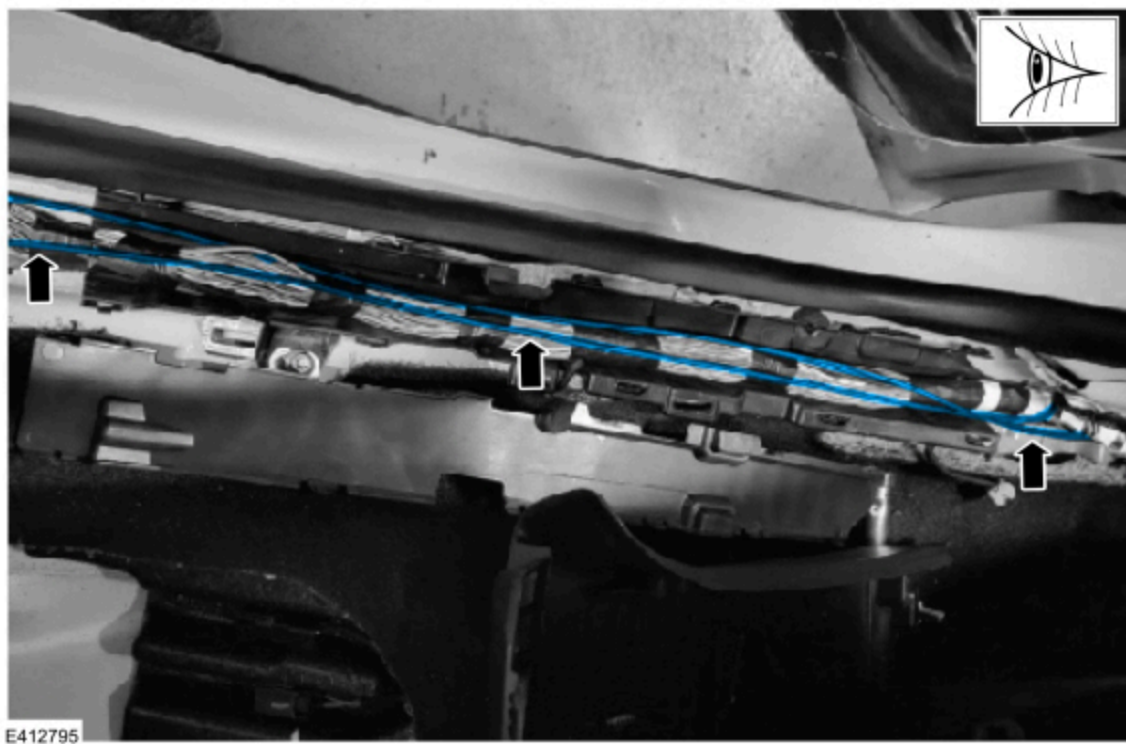
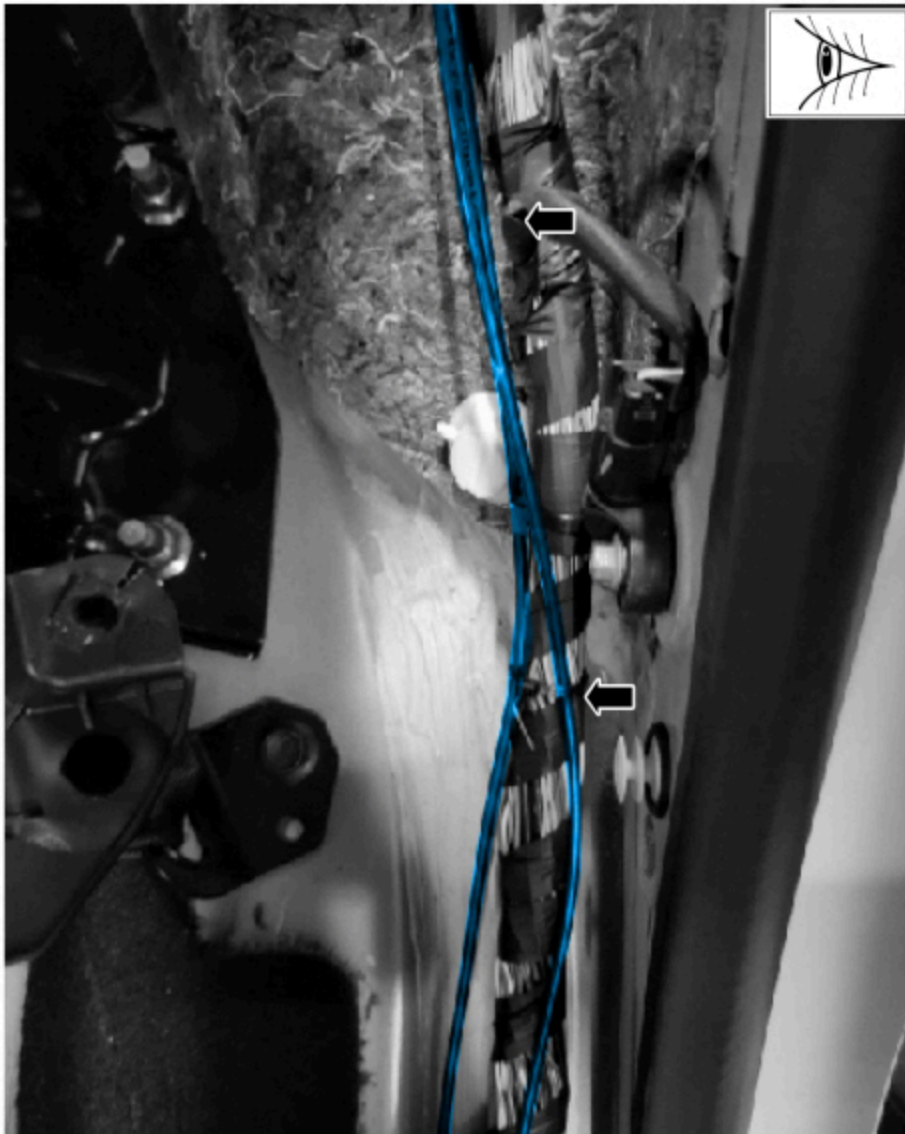

Figure 17



E412796

Figure 18



NOTE: Make sure to avoid kinking or routing the cable in such a way that it bends greater than 90 degrees over 30 mm (1.2 in), as sharp bends could damage the cable.

26. Is the vehicle equipped with Minor Feature Codes HKLAG, HKLAH, and/or J3QAD? To confirm a vehicle is built with a certain minor feature code, review the build information by double-clicking the VIN in the upper left corner in PTS.

(1). Yes - using small zip ties, overlay the new coaxial cable jumper to the C2563 connector found in the passenger footwell. (Figures 19-21) Once the new C2563 connector is in place, cut off original coaxial cable connectors. If extra cable length is present when routing the new coaxial cable, loop and stow the excess length. (Figure 21)

Figure 19



E412798

Figure 20



E412799

Figure 21

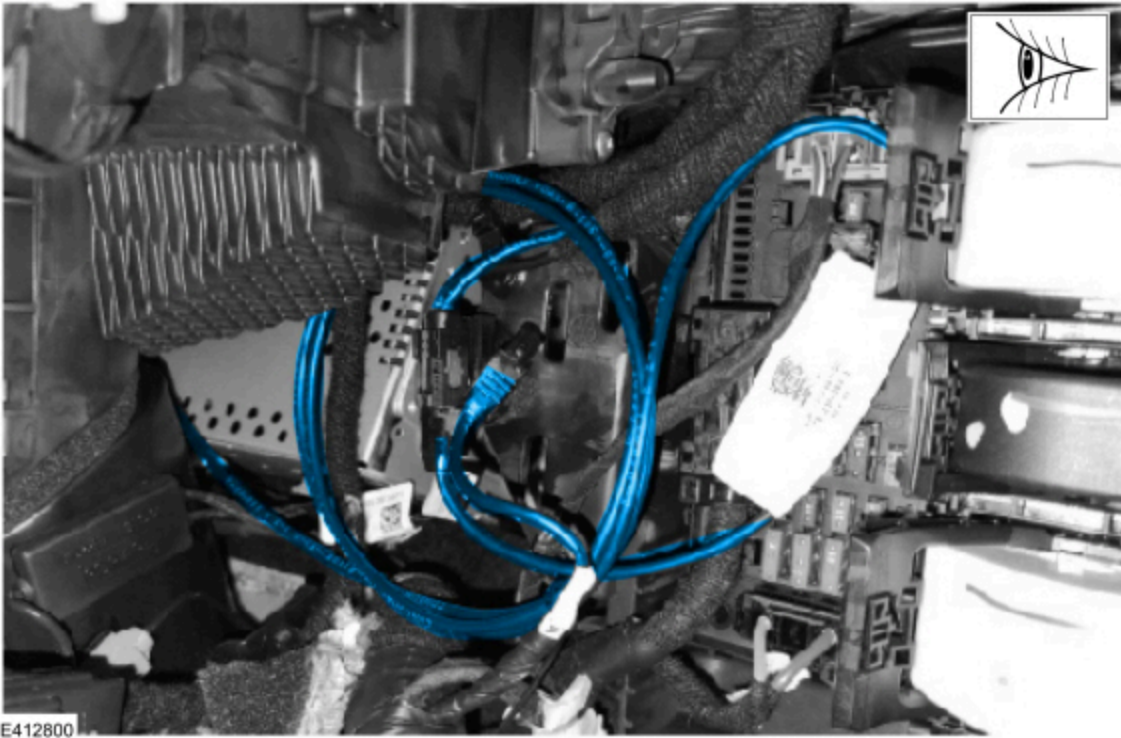

NOTE: Be sure to avoid kinking or routing the cable in such a way that it bends greater than 90 degrees over 30 mm (1.2 in), as sharp bends could damage the cable.

(2). No - proceed to Step 27.

27. Power the vehicle on and wait 30 seconds. Clear and retrieve DTCs. Is DTC C1001:31 and/or U3000:89 present in the IPMA?

(1). Yes - replace the IPMA Camera. Refer to WSM, Section 419-07 Lane Keeping System, Removal and Installation, Image Processing Module A (IPMA) Camera.

(2). No - proceed to Step 29.

28. Power the vehicle on and wait 30 seconds. Clear and retrieve DTCs. Is DTC C1001:31 and/or U3000:89 present in the IPMA?

(1). Yes - replace the IPMA. Refer to WSM, Section 419-07 Lane Keeping System, Removal and Installation, Image Processing Module A (IPMA).

(2). No - proceed to Step 29.

29. Is DTC U3000:49 stored in the IPMA?

(1). Yes - download and run the "IPMA - Reset the Image Processing Module A (IPMA) Learned Values" application in the FDRS. Then run the "IPMA - Image Processing Module A (IPMA) Alignment" application immediately after. If DTC U3000:49 is still present after completing the "IPMA - Reset the Image Processing Module A (IPMA) Learned Values" application, then replace the IPMA. Refer to WSM, Section 419-07 Lane Keeping System, Removal and Installation, Image Processing Module A (IPMA).

(2). No - repair is complete.

© 2025 Ford Motor Company

All rights reserved.

NOTE: The information in Technical Service Bulletins is intended for use by trained, professional technicians with the knowledge, tools, and equipment to do the job properly and safely. It informs these technicians of conditions that may occur on some vehicles, or provides information that could assist in proper vehicle service. The procedures should not be performed by "do-it-yourselfers". Do not assume that a condition described affects your car or truck. Contact a Ford or Lincoln dealership to determine whether the Bulletin applies to your vehicle. Warranty Policy and Extended Service Plan documentation determine Warranty and/or Extended Service Plan coverage unless stated otherwise in the TSB article. The information in this Technical Service Bulletin (TSB) was current at the time of printing. Ford Motor Company reserves the right to supersede this information with updates. The most recent information is available through Ford Motor Company's on-line technical resources.