

C-Pillar Trim Panel



Special Tool(s) / General Equipment

Interior Trim Remover

Removal

NOTE: *Left hand drive (LHD) shown, right hand drive (RHD) similar.*

NOTE: *Removal steps in this procedure may contain installation details.*

NOTE: *Left hand (LH) shown, right hand (RH) similar.*

1. Remove the loadspace trim panel.
Refer to: [Loadspace Trim Panel](#) (501-05 Interior Trim and Ornamentation, Removal and Installation) .
2. Remove the rear seatbelt retractor and pretensioner anchor bolt.
Torque : 30 lb.ft (40 Nm)

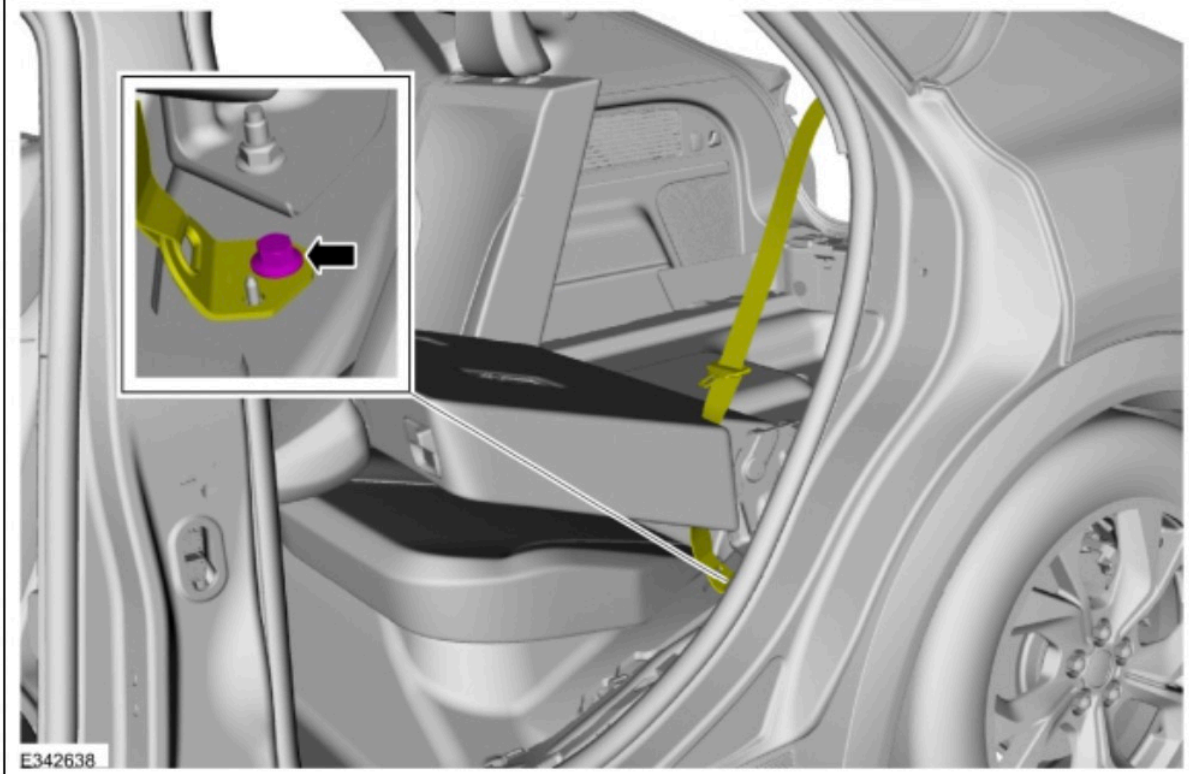

E342638

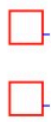

3. Position the liftgate weather strip aside.

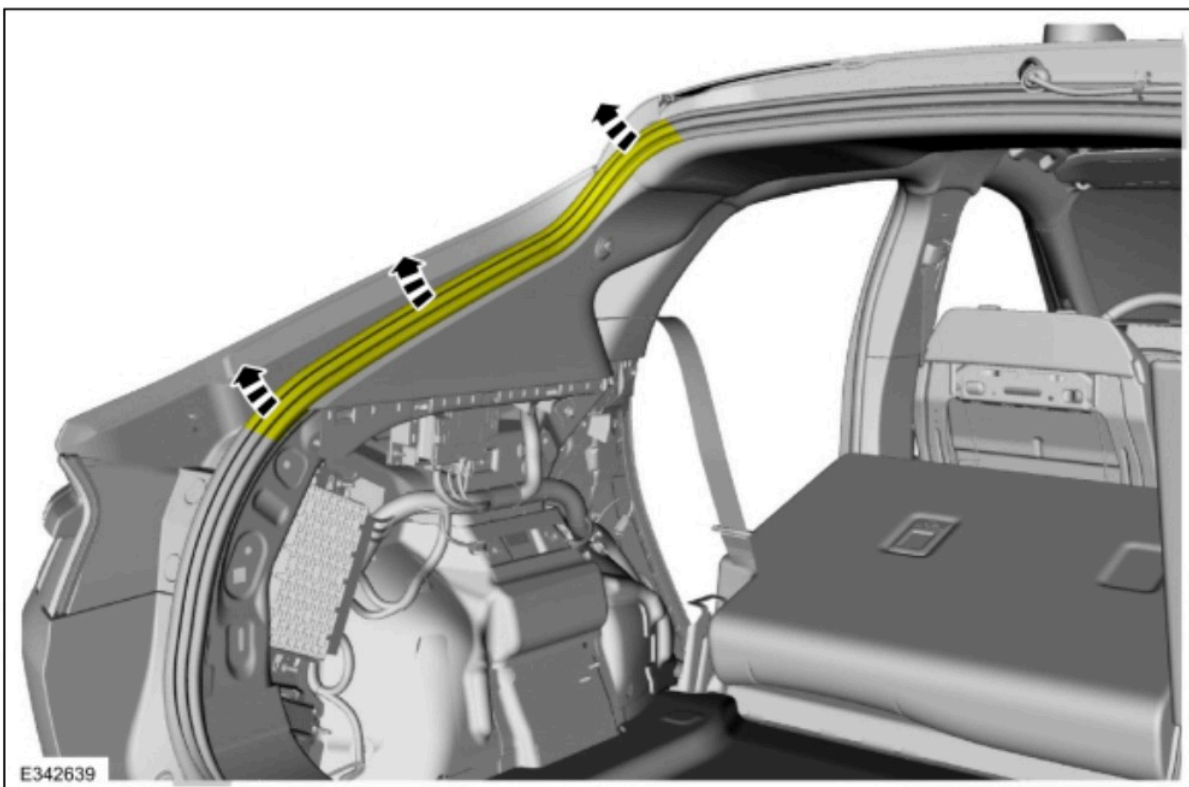

E342639

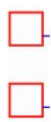

4. Remove the C-pillar trim panel bolt.

Torque : 106 lb.in (12 Nm)

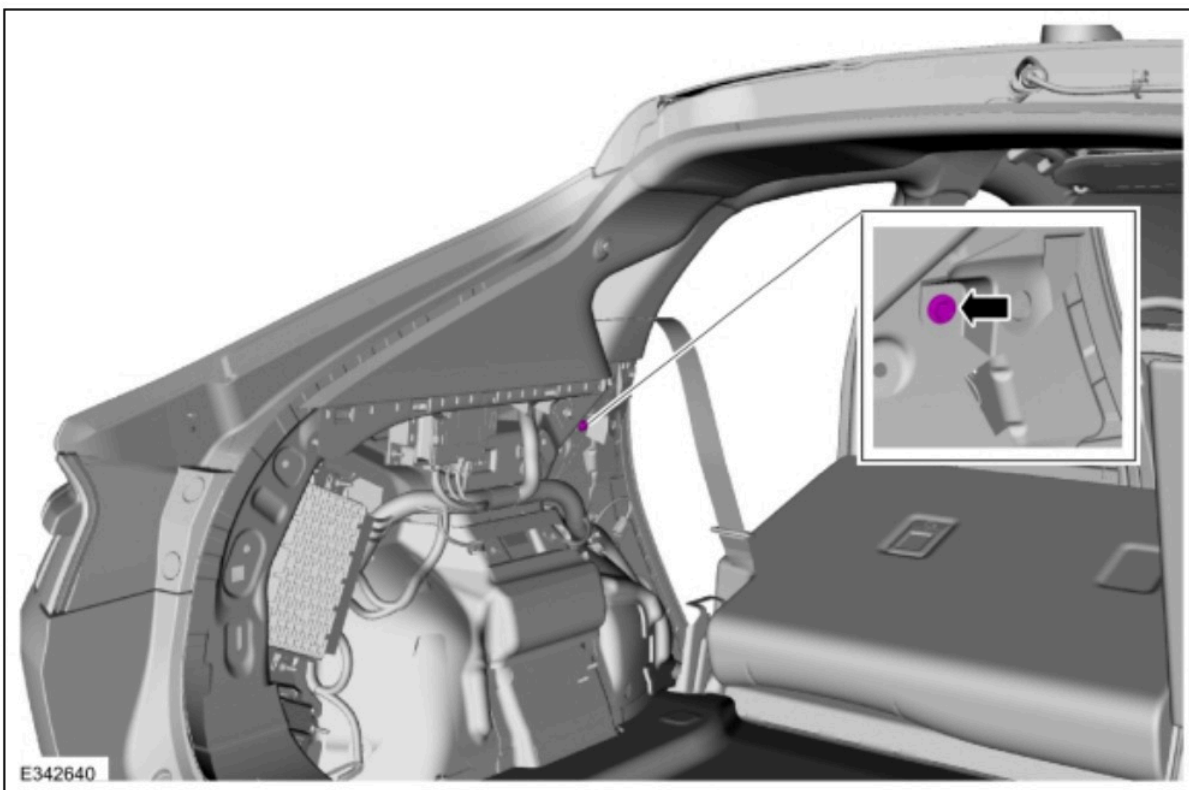

5. Release the tabs and position the rear seatbelt retractor and pretensioner cover aside.
Use the General Equipment: Interior Trim Remover

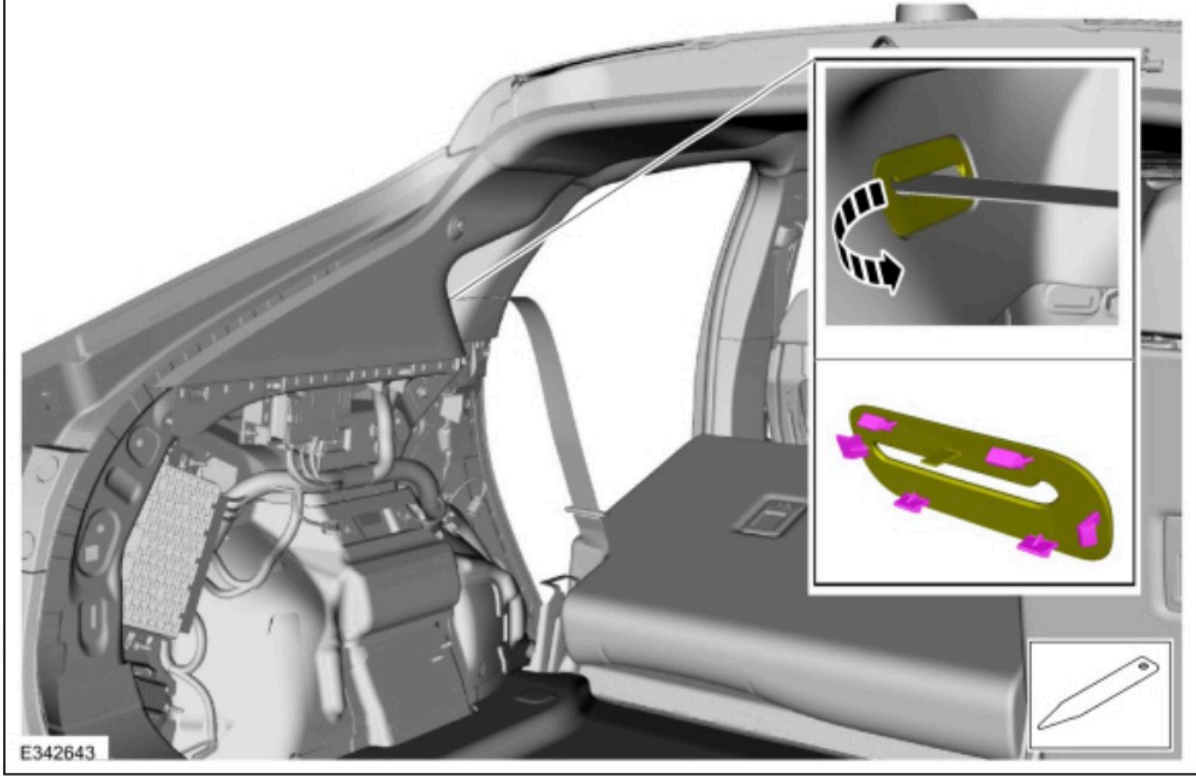

E342643

6. Release the C-pillar trim panel clips.
Use the General Equipment: Interior Trim Remover

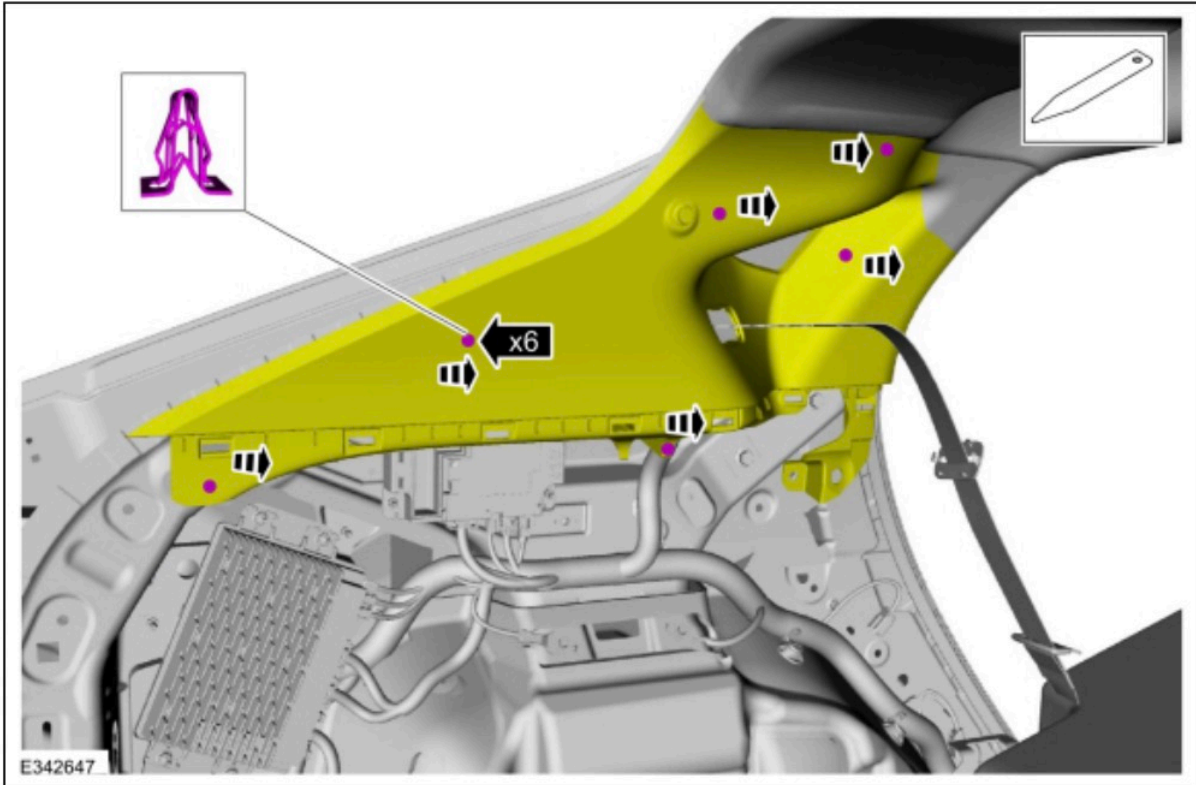

E342647

7. **NOTE:** The C-pillar trim panel must be positioned downward to allow the upper clip to release correctly. Failure to follow this direction may cause damage to the C-pillar trim panel.

Slide the C-pillar trim panel down, aligning the clip to the slot in the sheet metal.

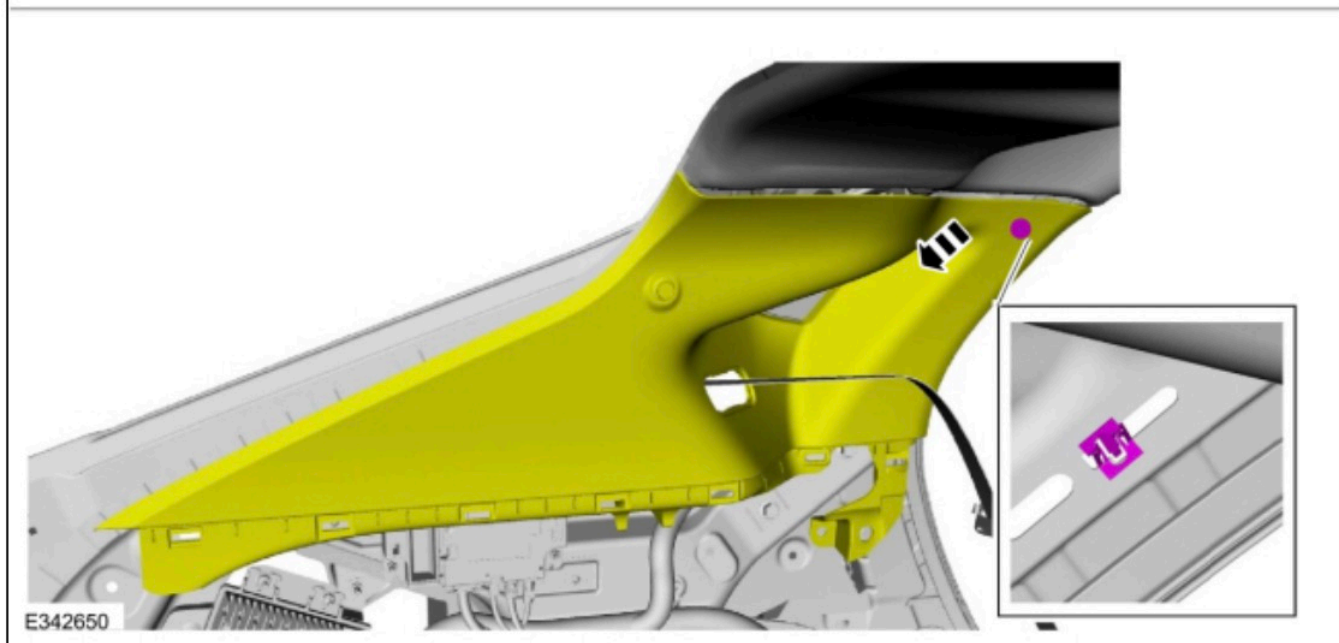
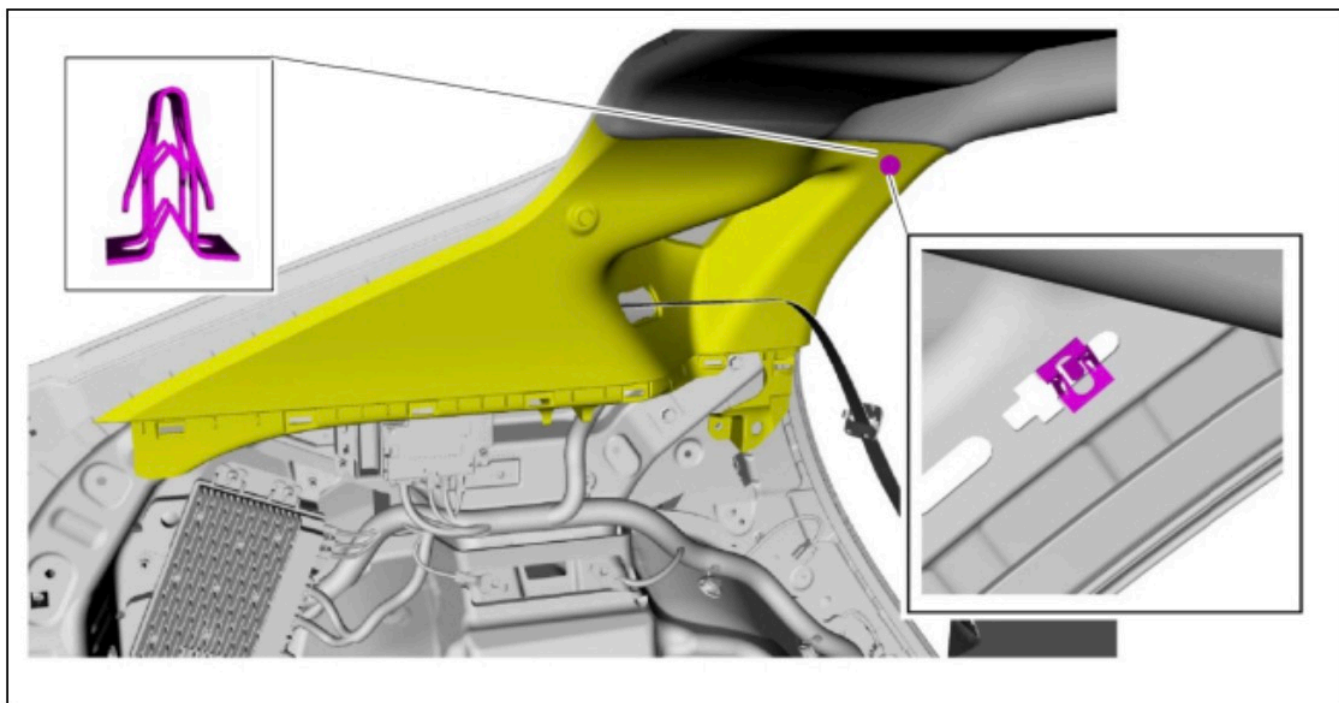

8. Remove the C-pillar trim panel.
1. Pull outward on the C-pillar trim panel.
 2. Feed the rear seatbelt retractor and pretensioner through the opening in the C-pillar trim panel.



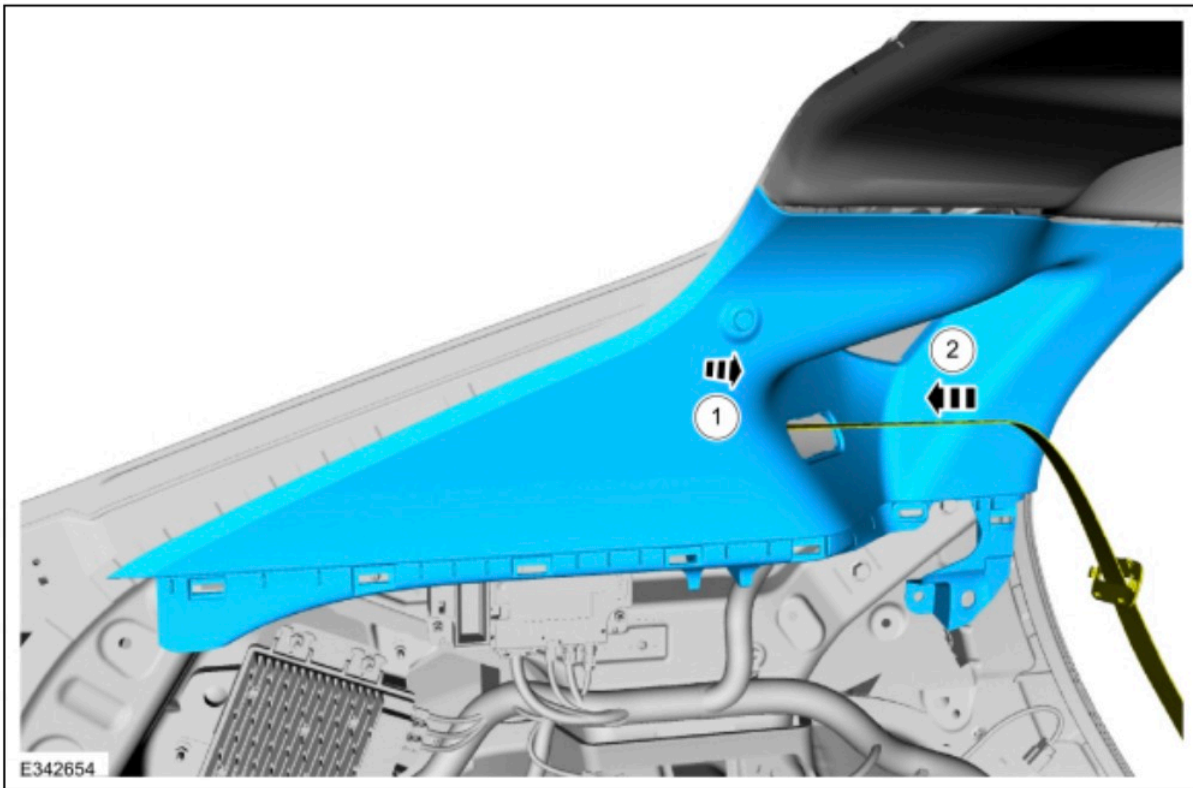

Installation

1. **NOTE:** *During installation, make sure the seatbelt webbing is not twisted and seatbelts and buckles are accessible to the occupants.*

To install, reverse the removal procedure.

2. Inspect and position the rear door weather strip lips so that it overlaps the top of the C-pillar trim panels.

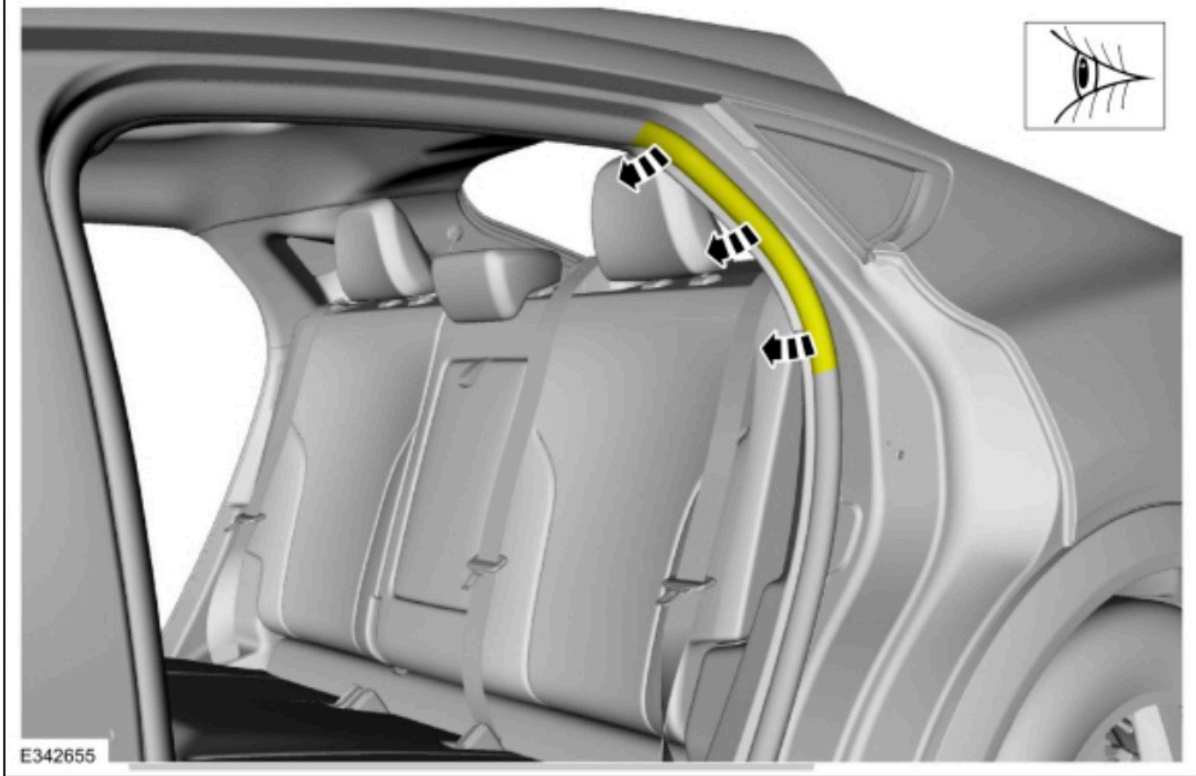

3. Check the seatbelt system for correct operation.
Refer to: [Seatbelt System Functional Tests](#) (501-20A Seatbelt Systems, General Procedures) .

© Copyright 2024, Ford Motor Company.