



Front Drive Halfshafts - Front Halfshaft LH

Mustang Mach-E 2021 (06/2019-)

 Print
  Report An Error

Removal and Installation

Special Tool(s) / General Equipment

 <p>14041</p>	204-161 Installer, Halfshaft
 <p>E153858</p>	205-D070 Remover, Front Wheel Hub
Tie Rod End Remover	
Tire Lever	

Removal

1. Refer to: [Wheel and Tire](#) (204-04A Wheels and Tires, Removal and Installation).
2. Refer to: [Front Undershield](#) (501-02 Front End Body Panels, Removal and Installation).
3. **NOTE:** This step requires the aid of another technician.

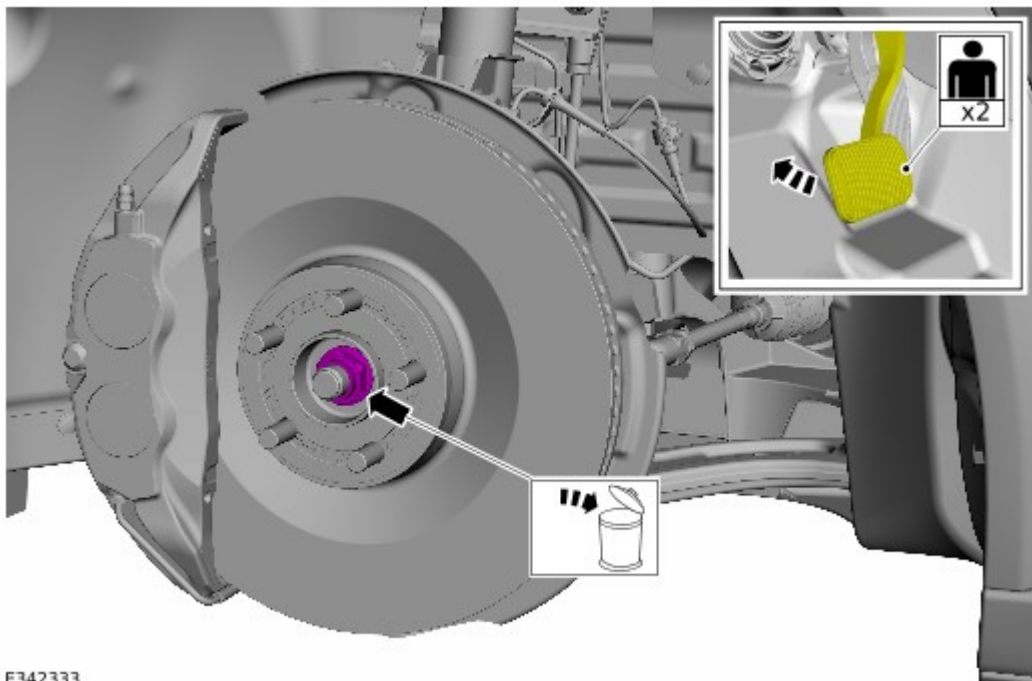

E342333

4.
 1. *Torque:* 11 Nm
 - 2.

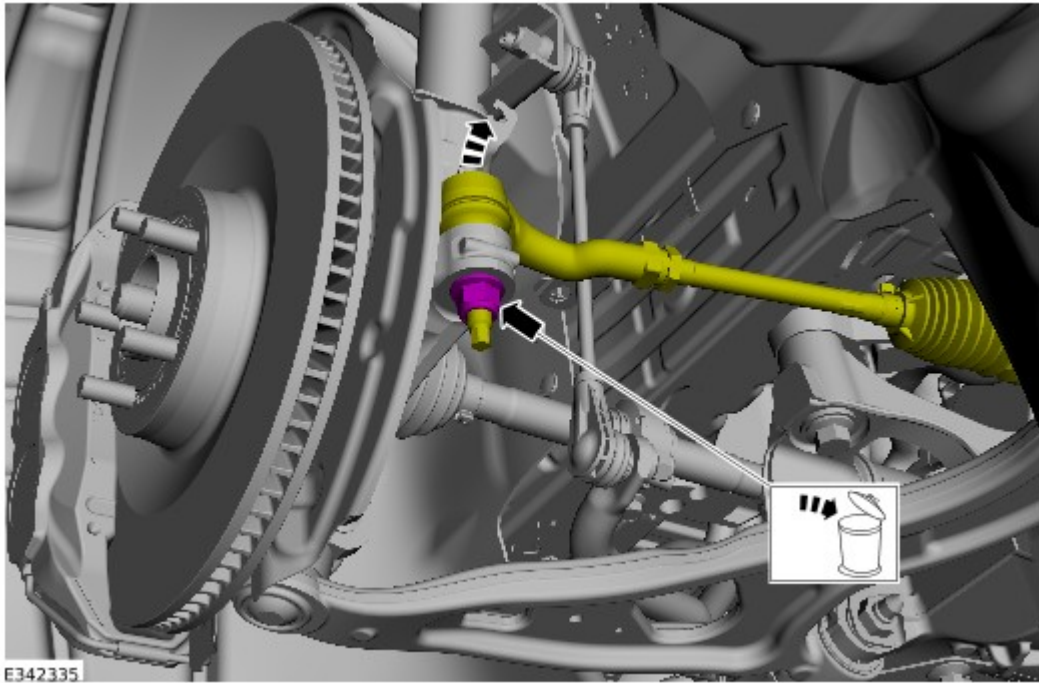

6. Torque: 110 Nm

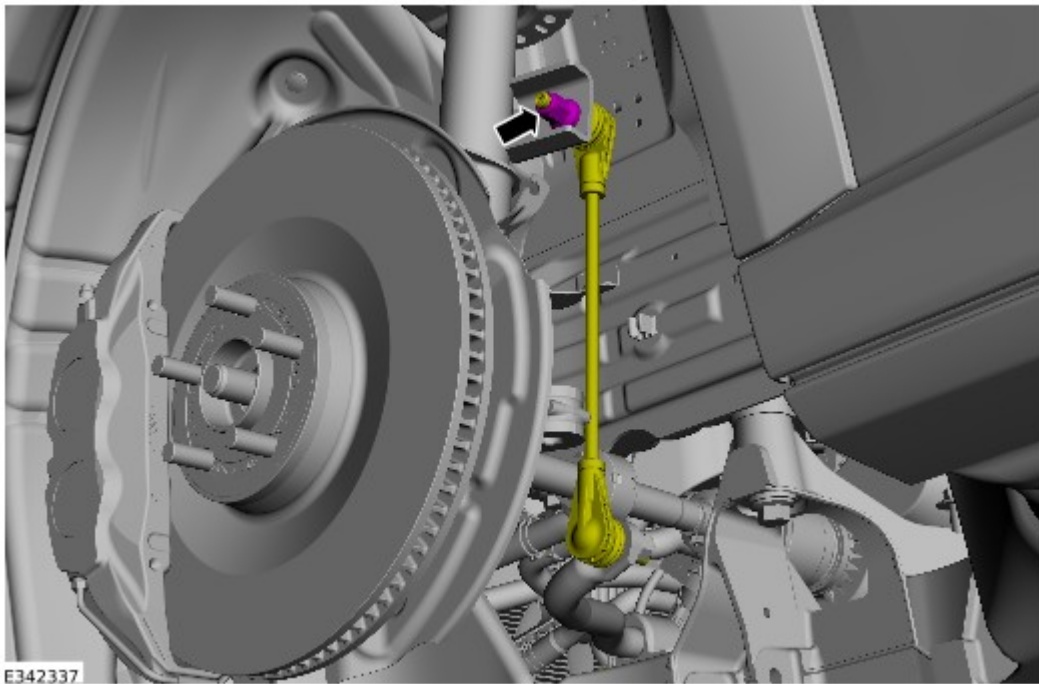

7. NOTICE:



The inner constant velocity (CV) joint must not be bent more than 18°.

The outer constant velocity (CV) joint must not be bent more than 45°.

Use Special Service Tool: [205-D070](#).

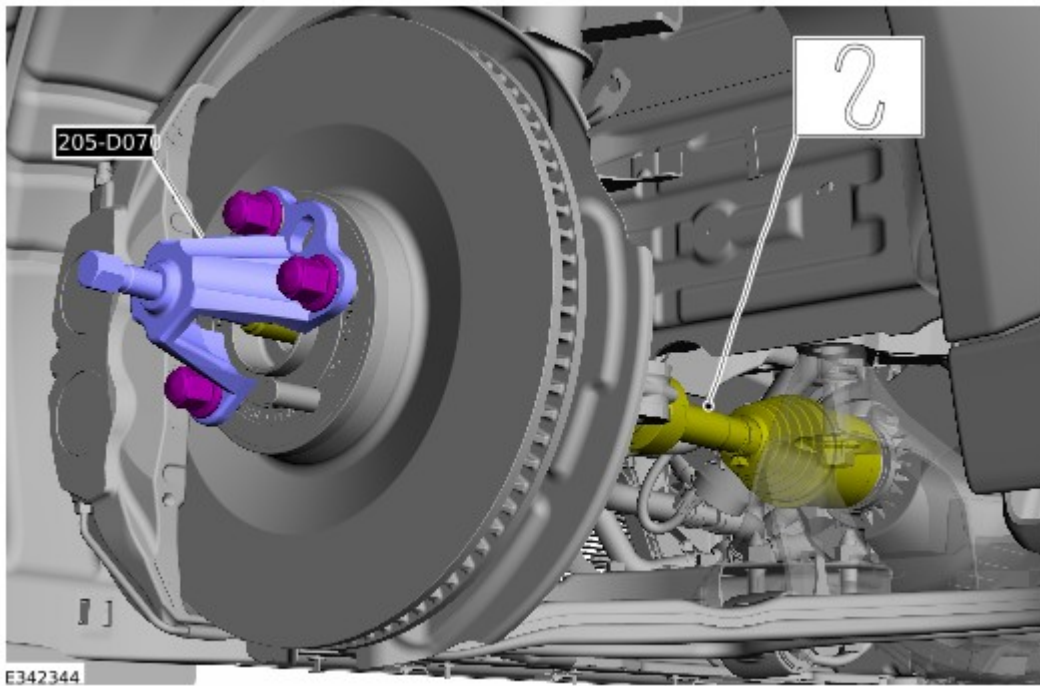

8. NOTICE:



Make sure that no load is placed on the brake hose.



Never allow the knuckle to hang from the upper and lower control arms or damage to the ball joints can occur.

1. Torque: 235 Nm

2.

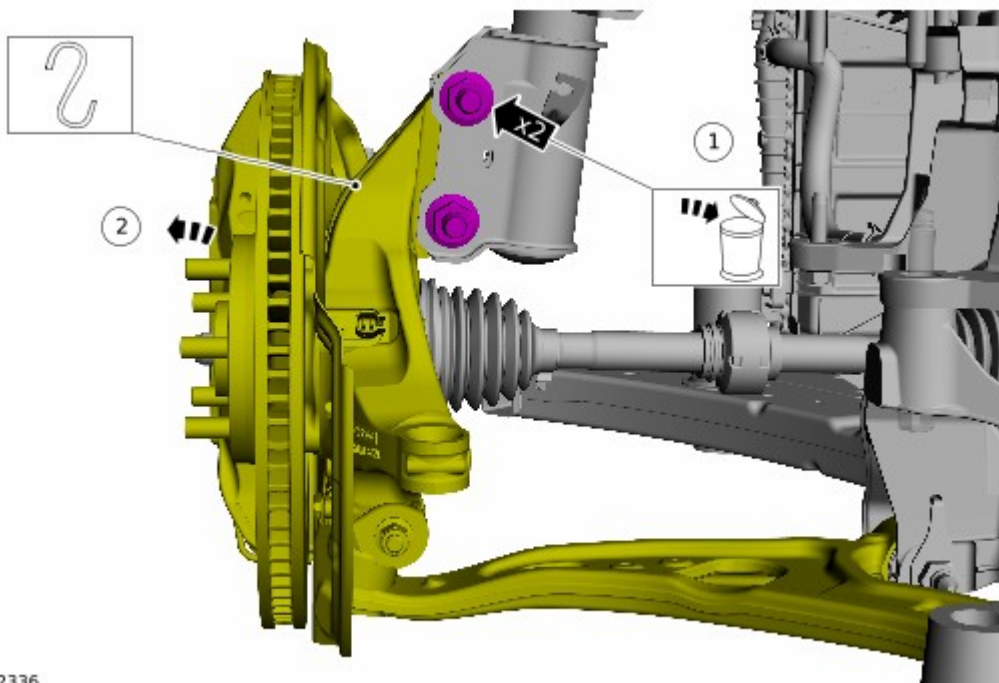

9. NOTICE:



Take extra care not to damage the mating faces.



Take extra care not to damage the seal.

Use the General Equipment: [Tire Lever](#)

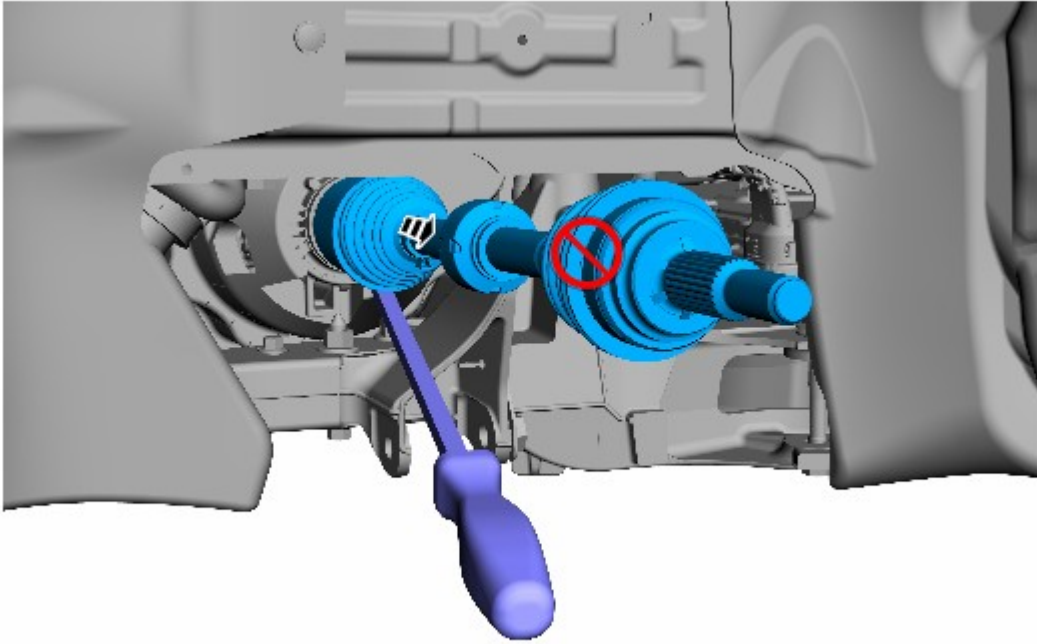

E342338

10.

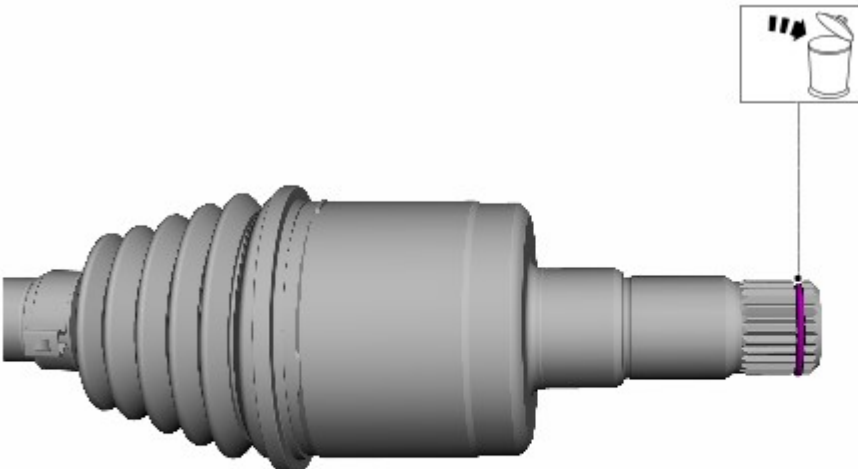

E342339

Installation

1. To install, reverse the removal procedure.
- 2.

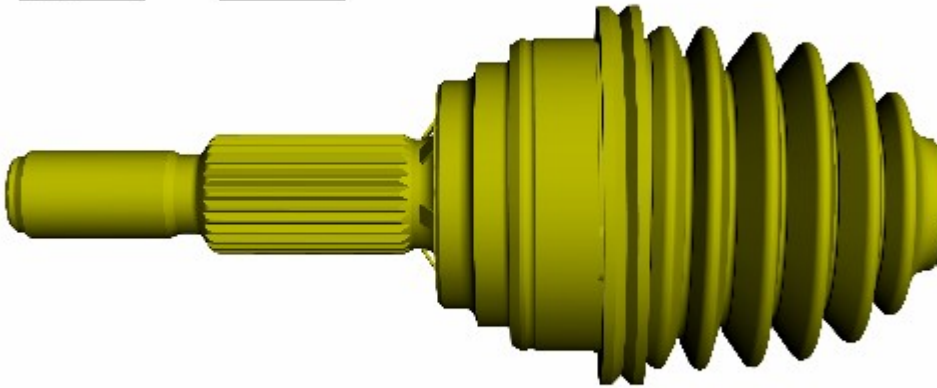

E342341

- 3.

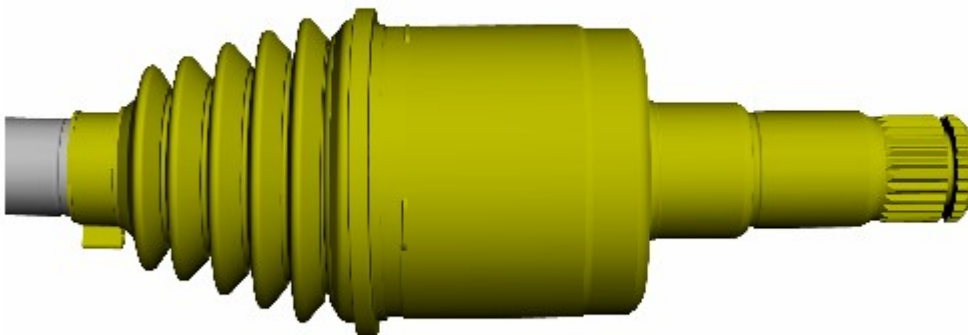

E342342

4. **NOTE:** Make sure new component is installed.
NOTE: Ensure that the circlip opening is aligned and oriented to 6 o' clock position.

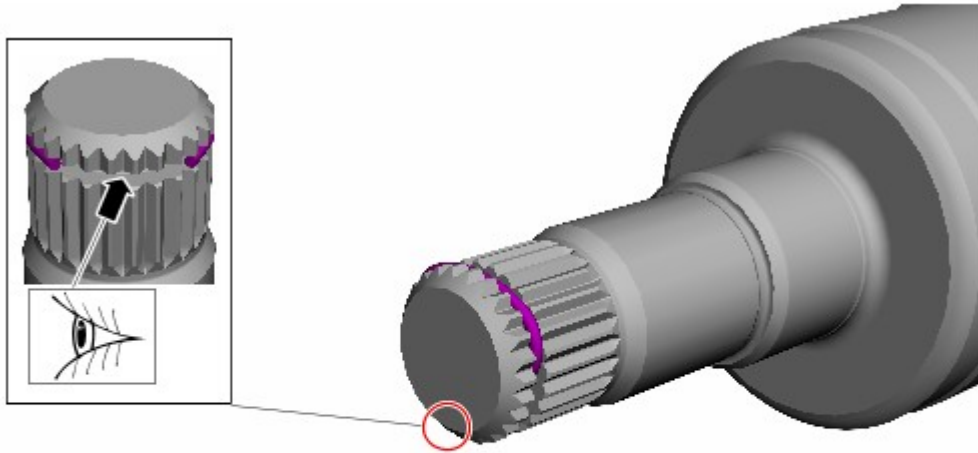

E342340

5. **NOTE:** Install a new component if it is damaged or has excessive wear.
NOTE: This step is only necessary when installing a new component.

Replace the halfshaft seal.

Refer to: [Halfshaft Seal LH \(302-01A Front Electric Drive Assembly - Base, Removal and Installation\)](#).

6. *Use Special Service Tool:* [204-161](#).

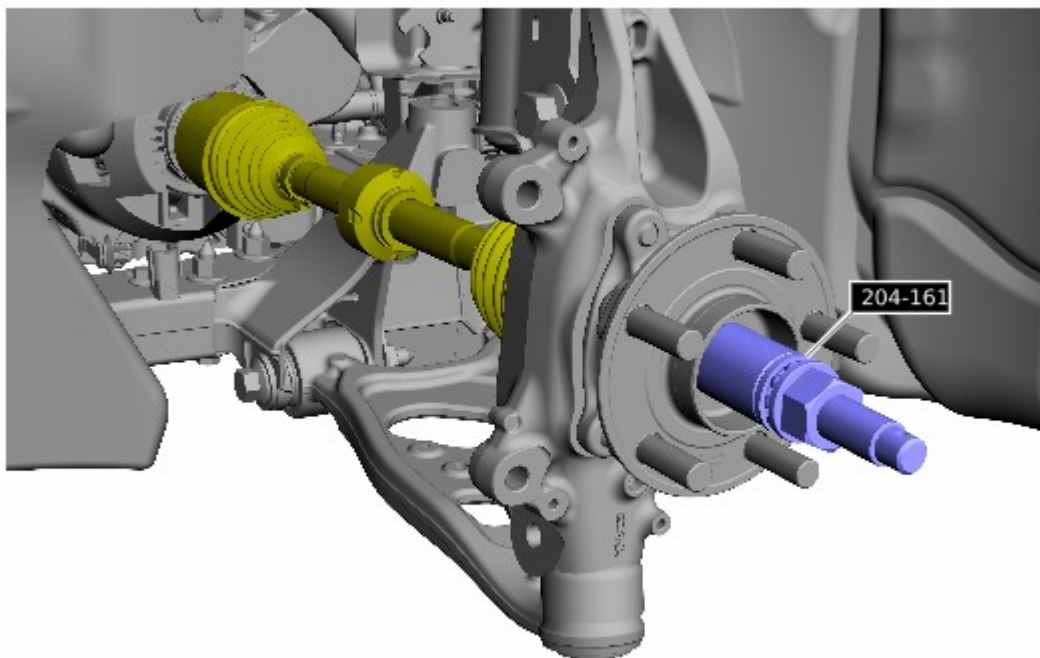

E342419

7. NOTICE:



Do not tighten the front wheel hub nut with the vehicle on the ground. The nut must be tightened to specification before the vehicle is lowered onto the wheels. Wheel bearing damage will occur if the wheel bearing is loaded with the weight of the vehicle applied.



Install and tighten the new wheel hub nut to specification in a continuous rotation. Always install a new wheel hub nut after loosening or when not tightened to specification in a continuous rotation or damage to the components may occur.

NOTE: This step requires the aid of another technician.

Torque:

Stage 1: 50 Nm

Stage 2: 200 Nm

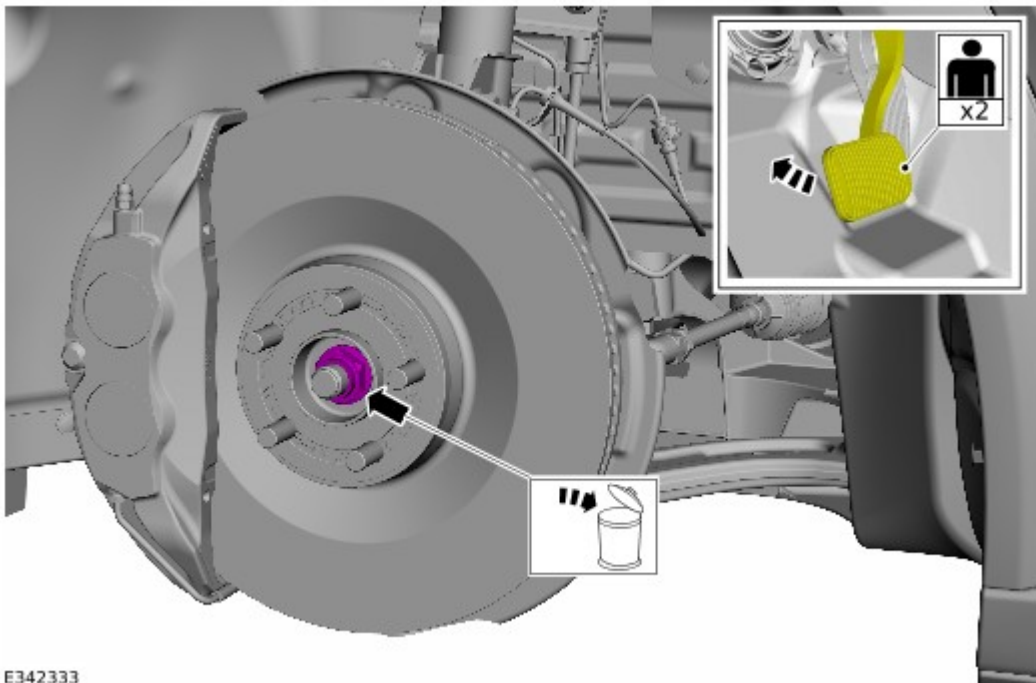

8. Refer to: [Drive Assembly Oil Draining and Filling](#) (302-01A Front Electric Drive Assembly - Base, General Procedures).