



GRIZZLE™

GRIZZLE™ MINI

MINI CONNECT

**USER MANUAL AND
INSTALLATION GUIDE**

UNIT-D
chargers



GRIZZL-E MINI CONNECT USER MANUAL

This manual is for the operation of the Grizzl-E MINI CONNECT EVSE. This manual includes information on the safety, installation, operation, moving, and storage of the EVSE. This document provides instructions for the listed model numbers and should not be used for any other product.

The user assumes full responsibility for ensuring the safe and correct use of this product. Failure to do so may result in injury or damage. Read all the instructions carefully and exercise caution when using this product.

Manual Revision: 1.9

July 16, 2025

Model Numbers:

- GRM-070-W-14-25DJ40-A-GB
- GRM-070-W-14-25SN40-A-GB



TABLE OF CONTENTS

1. IMPORTANT SAFETY INSTRUCTIONS	1
1.1 INSTRUCTIONS PERTAINING TO RISK OF FIRE OR ELECTRIC SHOCK.....	1
1.2 USER MAINTENANCE INSTRUCTIONS.....	2
1.3 MOVING, TRANSPORTING AND STORE INSTRUCTIONS.....	2
2. PRODUCT SPECIFICATIONS	3
3. INTRODUCTION AND UNPACKING	4
3.1 YOUR CHARGER.....	4
3.2 PACKAGE CONTENTS	5
4. INSTALLATION PLANNING AND SERVICE WIRING	6
4.1 ELECTRICAL SOURCE REQUIREMENTS	6
4.2 GROUNDING INSTRUCTIONS	7
4.3 GFCI.....	7
4.4 GRIZZL-E MINI ADAPTERS.....	7
5. MAXIMUM CURRENT OUTPUT	8
5.1 ADJUST MAXIMUM CURRENT BY DIP SWITCHES	8
6. INSTALLATIONS INSTRUCTIONS - MOUNTING BRACKET	11
7. EASYEVPLUG HOLSTER AND CABLE MANAGEMENT SYSTEM	12
8. OPERATION	13
8.1 CONNECT AND CHARGE.....	13
8.2 STOP CHARGING.....	13
9. CHARGING STATUS INDICATORS AND BUZZERS	14
9.1 INDICATOR LIGHTS.....	14
9.2 LED FAULT INDICATOR.....	15
9.3 SELF-MONITORING AND RECOVERY (AUTO RESTART).....	15
9.4 ERROR TROUBLESHOOTING.....	15
10. OCPP THROUGH GRIZZL-E CONNECT	16
10.1 CONNECT TO OCPP THROUGH GRIZZL-E CONNECT APP	16
10.2 APP FUNCTIONS	18
11. LOCAL SMART FEATURES	24
11.1 STATUS.....	24
11.2 TIMER.....	27
11.3 SETUP	30
11.4 ADVANCED	32
12. CHARGER WI-FI FEATURES	34
12.1 AUTOMATIC HIDDEN WI-FI	34
12.2 DISABLE SMART FEATURES	35
12.3 WI-FI CONNECTION RESET	36
WARRANTY	37

1. IMPORTANT SAFETY INSTRUCTIONS

This document contains instructions and warnings that must be followed when operating the Grizzl-E Mini Connect Level 2 Electric Vehicle Supply Equipment (EVSE). Before using the EVSE, read this document including any **WARNING** and **CAUTION** symbols.

The Symbols Used Have the Following Meanings



WARNING: risk of personal injury



WARNING: risk of fire



WARNING: risk of electric shock



















CAUTION: risk of damage to equipment

- This document provides instructions for the charging station and should not be used for any other product. Before installation of this product, review this manual carefully and consult with a licensed contractor, licensed electrician, or trained installation expert to ensure compliance with local building codes and safety standards.
- Consult a licensed electrician to ensure that this product can be safely installed.
- Ensure that the materials used, and the installation procedures, follow local building codes and safety standards.
- The information provided in this manual in no way exempts the user of responsibility to follow all applicable codes or safety standards.

1.1 INSTRUCTIONS PERTAINING TO RISK OF FIRE OR ELECTRIC SHOCK

Basic precautions should always be followed when using electrical products, including the following:

-   Read all the instructions before using this product.
-   Children should not use this device.
-   Do not put fingers into the EV connector.
-   Do not touch live electrical parts.
-   Do not use this product if the flexible power cord or EV cable is ragged, has broken insulation, or any other signs of damage.
-   Do not use this product if the enclosure or the EV connector is broken, cracked, open, or shows any other indication of damage.
-   To avoid a risk of fire or electric shock, do not use this device with an extension cord or electrical adapter.
-   Improper connection of the equipment grounding conductor can result in a risk of electric shock. Check with a licensed electrician if you are in doubt as to whether the product is properly connected and grounded.

SAVE THESE INSTRUCTIONS

1.2 USER MAINTENANCE INSTRUCTIONS

The EVSE does not require routine maintenance. Check before each charging session to ensure that cables and enclosure remain in good working order and no damage exists.

The exterior of the charging station is designed to be waterproof and dust proof (UL Type 4 Indoor/Outdoor Rating). However, periodic cleaning may be required.

To ensure proper maintenance of the charging station, follow these guidelines:

- Only use an automotive-grade soft cleaning cloth with soap and water to clean. Do not use cleaning solvents.
- Submerging the unit under water is not recommended.
- Ensure the output cable is stored on the holster after use to avoid damage.

Do not attempt to open, disassemble, repair, tamper with, or modify any components of the products. Contact Technical Support for any repairs.

1.3 MOVING, TRANSPORTING AND STORE INSTRUCTIONS

- When moving or lifting the unit, always grasp and carry by the charging station body. Never attempt to carry the unit by any of the electrical cables.
- Store the unit in a dry location, away from standing water.
- Store the unit at a temperature between -30C (-22F) to 70C (158F).



WARNING: This equipment is intended only for charging vehicles that do not require ventilation during charging. Please refer to your vehicle's owner's manual to determine ventilation requirements.



WARNING: The service wiring in this section is specific to North America. Before installing the charging station, identify the type of utility connection on site. If you are unsure about the available connection on the service panel, contact a licensed electrician.

FCC Declaration of Conformity



This charging station complies with part 15 of the FCC Rules. Changes or modifications to the charging station not expressly approved by the manufacturer could void FCC compliance.

1. This charging station does not cause harmful interference
2. This device accepts any interference received, including interference that may cause undesired operation.

2. PRODUCT SPECIFICATIONS

Description	Specifications
EVSE Level	AC Level 2 / AC Level 1
Connector Type	SAE J1772 or NACS
Electrical Circuit / Input Power Requirements	Dedicated Single Phase 208-240VAC 50/60 Hz. Branch Breaker: Double pole OR Dedicated Single Phase 110-120VAC 50/60 Hz.
Maximum Output Rating	40A; 9.60kW with 50A Circuit Rating
Alternate Adjustable Output Ratings	240V Outlet 39A; 9.36kW - 7A; 1.9kW 120V Outlet 12A; 1.44kW - 7A; 0.84kW
Input Power Connection	Plug in NEMA 14-50
Installation Rating	UL Type 4, Indoor/Outdoor Rated
Operational Ratings	Temperature -22F to 122F (-30C to 50C) Humidity: 95% non-condensing
Enclosure Dimensions	Length: 175mm (6.9in) Width: 80mm (3.1in) Height: 60mm (2.4in)
Overall Weight	9.8lbs (4.4kg)
Display and Indicators	LED Charge Status Indicator (Amperage Setting, Ready/Charging, Charging Fault)
Charge Cable Length	25ft (7.6m)
Connectivity	2.4Ghz Wi-Fi network
Certification	UL Certified E510712

3. INTRODUCTION AND UNPACKING

3.1 YOUR CHARGER

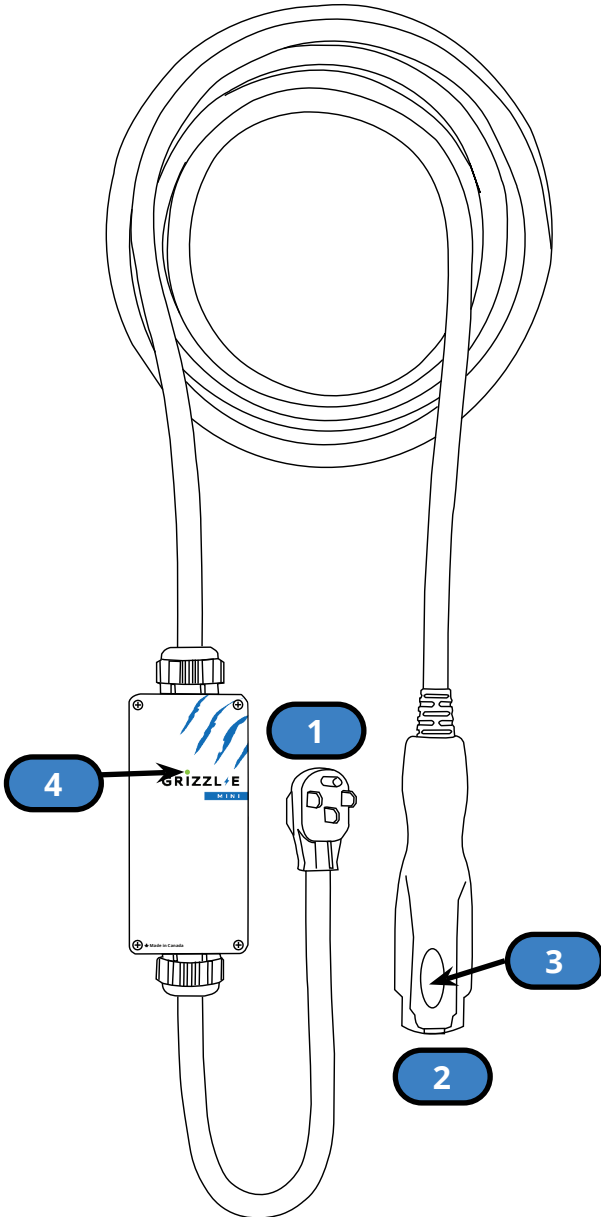

Charger Components

1. Input Cable 14-50P
2. Output Cable J1772 Connector
3. Latch Release Button
4. Indicator Light

3.2 PACKAGE CONTENTS

Mounting Kit

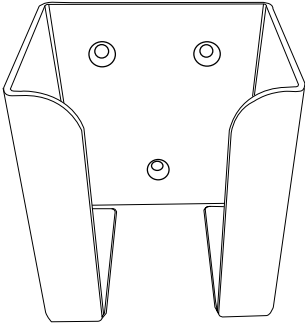

Mounting Bracket

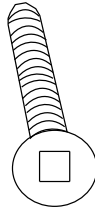

Mounting Screw
(x4)

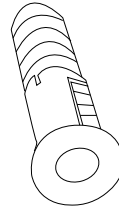

Anchor (x4)

Electrical Adapters

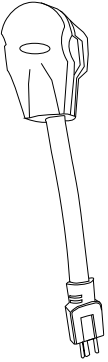

NEMA 14-50R to
NEMA 5-15P

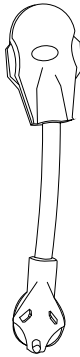

NEMA 14-50R to
NEMA TT-30P



NEMA 14-50R to
NEMA 14-30P

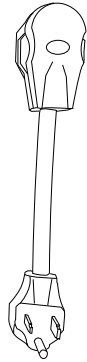

NEMA 14-50R to
NEMA 6-50P

Holster Kit

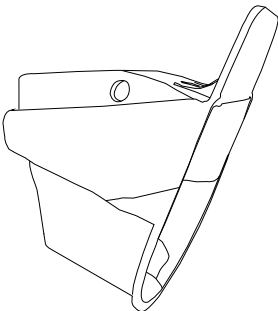

EasyEVPlug
Holster

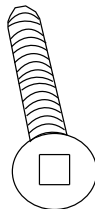

Mounting Screw
(x4)

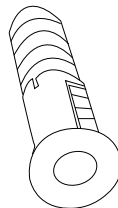

Anchor (x4)

4. INSTALLATION PLANNING AND SERVICE WIRING



WARNING: Disconnect the power supply to the charging station before installing or adjusting the charging station. Failure to do so may result in physical injury or damage to the power supply system and the charging station.



WARNING: To reduce the risk of fire, connect only to a circuit provided with 12-50 amperes maximum branch circuit overcurrent protection requirements in accordance with the National Electrical Code ANSI/NFPA 7- and the Canadian Electrical Safety Code, Part 1, C22.1. If you are unsure if your circuit meets these requirements consult a qualified electrician.

4.1 ELECTRICAL SOURCE REQUIREMENTS

Prior to using Grizzl-E Mini ensure the electrical source that can support the following Input Requirements for the Charging Station Per local Electrical Safety Code requirements:

- 208-240VAC 16A-40A or 110-120VAC 7A-12A Dedicated Circuit
- A Double Pole Circuit Breaker of the circuit rating must be used.
- Requirements govern that only 80% of the circuit rated load may be utilized.
- The Charging Stations can connect a Standard NEMA 14-50 Receptacle, or the provided adapters can be used.



WARNING: Grizzl-E Mini must use the original NEMA 14-50 plug. Do not attempt to disassemble unit to hardwire or change the plug. Doing so will void the warranty. Do not modify the plug provided with the product – if it does fit the outlet, have a proper outlet installed by a qualified electrician.

4.2 GROUNDING INSTRUCTIONS

This product must be grounded. If it should malfunction or break down, grounding provides a path of least resistance for electric current to reduce the risk of electric shock.

This product is equipped with a cord having an equipment grounding conductor and a grounding plug. The plug must be plugged into an appropriate outlet that is properly installed and grounded in accordance with all local codes and ordinances.

An insulated grounding conductor that is identical in size, insulation material, and thickness to the grounded and ungrounded branch-circuit supply conductors, except that it is green with or without one or more yellow stripes, shall be installed as part of the branch circuit that supplies the device or system.

The grounding conductor described in item 1 shall be grounded to earth at the service equipment or, when supplied by a separately derived system, at the supply transformer.



WARNING: Improper connection of the equipment-grounding conductor is able to result in a risk of electric shock. Check with a qualified electrician or serviceman if you are in doubt as to whether the product is properly grounded.

4.3 GFCI

The Charger is equipped with GFCI. Additional downstream GFCI is not required. In locations where GFCI at the outlet is mandated by code, the charger will not experience adverse effects.

4.4 GRIZZL-E MINI ADAPTERS

Grizzl-E Mini can work with either a 240V or 120V dedicated circuit.

Grizzl-E Mini will automatically detect the outlet voltage and adjust settings based on the voltage.

Grizzl-E Mini can work with the following adapters:

- NEMA 14-50R - NEMA 5-15P. 110-120V VAC. Max 12A.
- NEMA 14-50R - NEMA TT-30P. 110-135 VAC. Max 24A.
- NEMA 14-50R - NEMA 14-30P. 208-240 VAC Max 30A.
- NEMA 14-50R - NEMA 6-50P. 208-240 VAC. Max 50A.

5. MAXIMUM CURRENT OUTPUT

The GRIZZL-E Mini EVSE has the ability to adjust the maximum current output from 7A-40 using either Smart Features or DIP switches. For more information on setting the current limit through Smart Features.

Requirements govern that only 80% of the circuit-rated load may be utilized. The charging station default factory maximum current output setting is 40A.

5.1 ADJUST MAXIMUM CURRENT BY DIP SWITCHES

If local electrical codes require a physical switch to govern the maximum current settings, adjust the DIP switch settings:

1. Ensure the unit is unplugged. Secure the Charging Station on a flat surface with the front cover facing out.
2. Remove the front cover by removing the 4 screws at each corner of the charging station. Use 7/64" (2.5mm) hex key to remove cover screws.



CAUTION: The LED pipe is attached to the front cover. When the front cover is removed, place it on a flat surface facing down to avoid damage to the LED pipe.

3. Locate the DIP switch on the charging station circuit board. The DIP switch is a 4-position switch on the main circuit board.

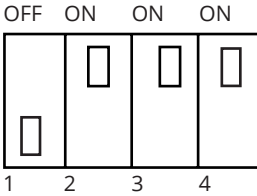

WARNING: Do not touch live electrical parts. Disconnect the power supply to the charging station before adjusting the DIP Switches. Failure to do so may result in physical injury or damage to the power supply system and the charging station.

4. Adjust the DIP Switches to 40A, 32A, 24A, or 16A using the following combination of DIP Switch Settings:

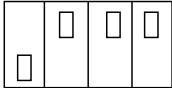
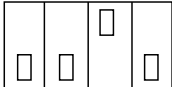
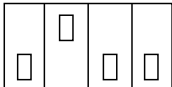
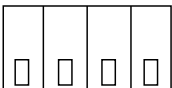
Maximum Current Output	Switch 1	Switch 2	Switch 3	Switch 4	DIP Switch Setting
40A Maximum Current Output (Factory Default Setting)	OFF	ON	ON	ON	
32A Maximum Current Output	OFF	OFF	ON	OFF	
24A Maximum Current Output	OFF	ON	OFF	OFF	
16A Maximum Current Output	OFF	OFF	OFF	OFF	

Once the DIP Switch Setting is adjusted, reassemble the charging station. Reinstall the top cover to the charging station using the following torque force to secure the 4 cover screws:

Screw	Torque
PH2	16 kgf-cm 13.88 lb-in

6. INSTALLATIONS INSTRUCTIONS – MOUNTING BRACKET

Prior to mounting, determine the location of an acceptable mounting support. All charging station products must be anchored into a mounting support such as a 2" x 4" stud or a solid concrete wall. **DO NOT** mount this unit directly to a stucco/drywall/wall board.

1. Secure the back piece of the mounting bracket to the wall or other suitable structure using the Mounting screws.

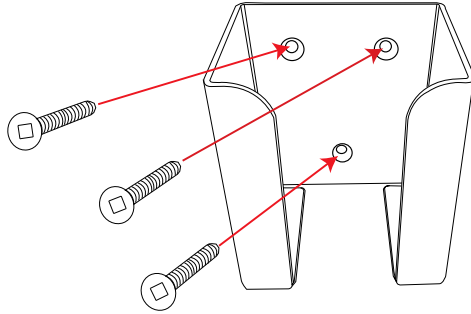

This device shall be mounted at a sufficient height from grade such that the height of the storage means for the coupling device is located between 0.6m (24") and 1.2 m (48") from grade.

2. Slide the Mini Grizzl-E down into the mounting bracket. Slide the Grizzl-E Mini up out of the mounting bracket for a portable charger.

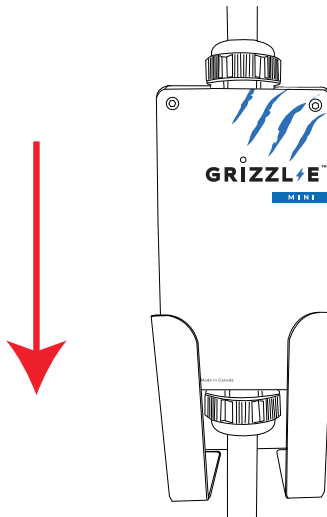

The EVSE shall be installed with the power supply cord managed so that it cannot contact the floor once the EVSE is installed and plugged into the outlet.

7. EASYEVPLUG HOLSTER AND CABLE MANAGEMENT SYSTEM

The EasyEVPlug™ Holster or Tesla EasyEVPlug™ Holster is the new innovative method to protect your plug and manage your cord. It has the following features:

- No need to aim – flawless plug even in the dark.
- Your EV holster will always be in a convenient location.
- Saves space – special angle for less wall clearance.
- Integrated cable management – holds up to 25 feet of cable.

The EasyEvPlug holster can be installed at any location near the charging station.

1. Hold the back of the holster against the mounting surface. Fasten Phillips head screws through back holes. Use anchors if attaching directly to drywall.

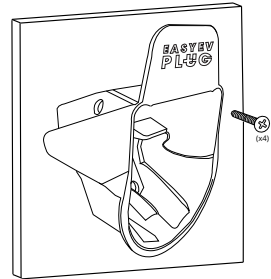

2. Insert the charging connector into the holster.

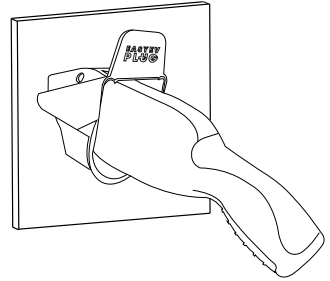

3. Wrap cable on top of EasyEvPlug.

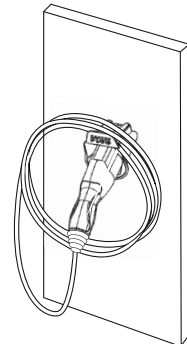

8. OPERATION

8.1 CONNECT AND CHARGE

J1772

1. Press down on the latch release button. Ensure latch release button is fully compressed.
2. Insert the charging Connector into the EV and ensure the connector is fully seated/locked in place.
3. Release the latch release button.

NACS

Insert charging connector into the EV and ensure the connector is fully seated/locked in place.

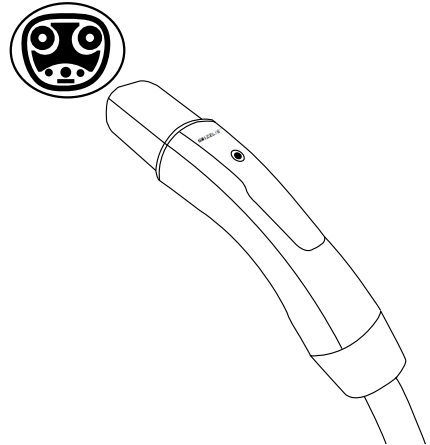
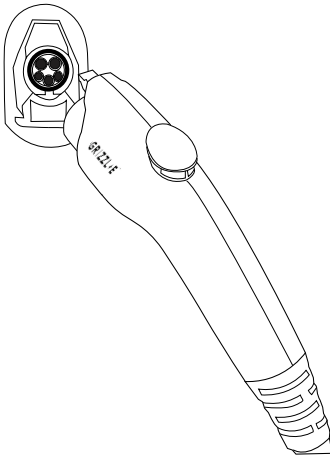

8.2 STOP CHARGING

J1772

1. Press down on the latch release button. Ensure latch release button is fully compressed.
2. Remove the Charger Connector from the EV
3. Return the connector to the holster.

NACS

1. Remove the Charger Connector from the EV
2. Return the connector to the holster.













WARNING: DO NOT tamper with the device. No User Serviceable parts inside.

9. CHARGING STATUS INDICATORS AND BUZZERS

9.1 INDICATOR LIGHTS

Grizzl-E Min Connect uses the following indicator lights for the charger status:

LED Indicator	Buzzer	Description	Definition
	No buzzer	White Steady	Initialization
	No buzzer	Magenta Steady	Charger Ready. Not connected to server.
	No buzzer	Blue Steady	Charger Ready. Connected to Server
	No buzzer	Blue Flashing	Vehicle detected. Ready to Charge.
	No buzzer	Green Flashing	Charging in progress.
	No buzzer	Green Steady	Charging complete. Stopped by vehicle.
	No buzzer	Yellow Steady	Vehicle not detected. Charging restricted by Smart Features.
	No buzzer	Yellow Flashing	Vehicle Detected. Charging restricted by Smart Features.
	No buzzer	Green + Yellow Alternating	Charging Not Complete + Charging restricted by Smart Features.
	Buzzer beeps	Red Flashing	Fault.

9.2 LED FAULT INDICATOR

When Grizzl-E Mini experiences an error, the red light will flash, and the buzzer will beep a specific number of times. The cycle will pause for 1 second and repeat.

The number of red flashes and beeps indicates the type of fault:

LED Indicator	# of Flashes	Error Description
Red Flashing	1	Lost ground
Red Flashing	2	GFCI High Leakage
Red Flashing	3	Relay is stuck
Red Flashing	4	GFCI Low Leakage
Red Flashing	5	High temperature of the module
Red Flashing	7	Vehicle Communication Error
Red Flashing	8	Undervoltage
Red Flashing	9	Diode error
Red Flashing	10	Over Current
Red Flashing	12	Application Error
Red Flashing	13	GFCI Self-Test Failure
Red Flashing	14	Overvoltage

9.3 SELF-MONITORING AND RECOVERY (AUTO RESTART)

When a charging session is interrupted due to a temporary error condition, it will automatically restart when the cause of the temporary error condition returns to normal. The status indicator lights flashes RED, with the number of flashes indicating the error condition.

- All error conditions can Self-Recover if the error condition is cleared.
- The charger will automatically reset if the error condition is cleared. If the error condition is not cleared the charger will continue to display a RED error light.
- If the error condition occurs within 5 seconds of the start of a charging session a permanent fault will trigger.

9.4 ERROR TROUBLESHOOTING

If the charger is not able to auto-recover, follow these steps:

1. Unplug the charging connector from the vehicle.
2. Count the number of flashes to identify the error type.
3. Unplug the charging station or switch the upstream circuit breaker to the OFF position.
4. Wait 1-2 minutes, then plug the charging station back in.
5. Confirm the Fault light is no longer present.
6. If the Fault light remains, please contact United Chargers Technical Support. Indicate the number of red flashes and error type.

10. OCPP THROUGH GRIZZL-E CONNECT

10.1 CONNECT TO OCPP THROUGH GRIZZL-E CONNECT APP

Connect charger to local Wi-Fi network to use OCPP and the Grizzl-E Connect Application for iOS or Android.

OCPP Grizzl-E Connect settings will override local smart features described in [11. Local Smart Features](#).

Step 1: Connect Charger to Wi-Fi

1. Connect to the charger's Wi-Fi Network. The network name is the **serial number**. Stay on the network even though there is no internet connection.

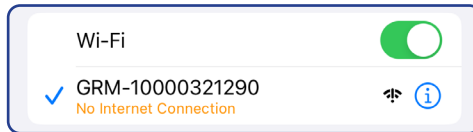

2. Open your web browser. Enter the IP address 192.168.4.1 to open the local connection page. Disable cellular data if page will not load.

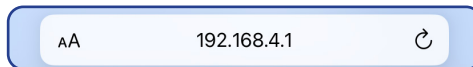

3. In the Local Wi-Fi Connection go to the Setup tab.

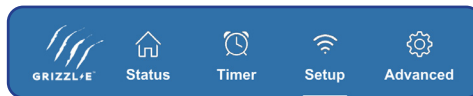

4. Go to the **WiFi connect configuration** section.

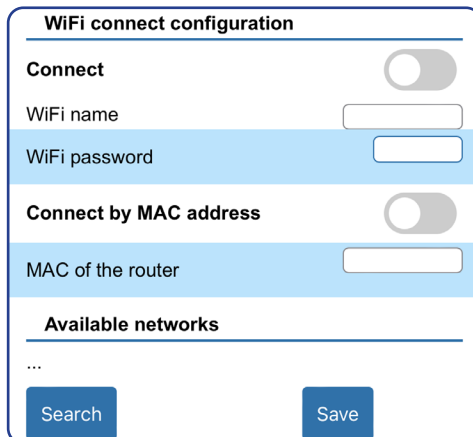

5. Select the Search button to show the list of available networks.
6. Select your network from the list of available networks. Click directly on the network name. The network name will populate the Wi-Fi name field. Ensure network is 2.4 GHz and has a signal strength greater than -67 RSSI (optimal range -40 to -60 RSSI).

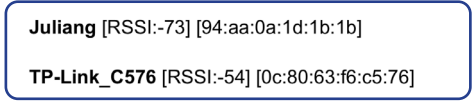

7. Enter the Wi-Fi Password.
8. Enable the **Connect** button.

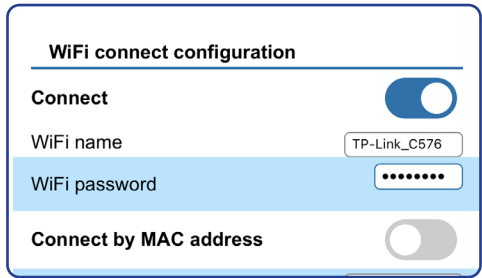

9. Select the **Save** button.
10. Select the **Confirm** button to apply new settings.

Step 2: Add Charger to Account

1. Download the Grizzl-E Connect app for iOS or Android.



2. Create an Account and sign in.
3. Select the + button to add a new device. Select your model from the list of devices.
4. Select the **Scan Serial Number** button. Use camera to scan the QR code on the label.
5. Select the **Add Charger to Account** button.

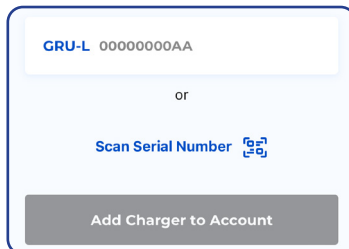

10.2 APP FUNCTIONS

Home Page



1. **Dashboard:** Select a charger or add a new charger.
2. **Account Settings:** Edit account and profile settings.
3. **Charger Serial Number**
4. **Charger Connectivity Status**
5. **Charger Status:** Ready to Charge, Charging, Disabled, Scheduled, Error or Off-line.
6. **Disable:** Unit will not charge when plugged into vehicles. Overrides existing schedules.
7. **Charge Now:** Unit will automatically start charging when plugged in the vehicle.
8. **Scheduled:** Charger will follow set schedule. Select Edit Schedule to set schedule.
9. **Charging History:** View [History](#).
10. **Edit Schedule:** Set [Schedule](#).
11. **Charger Settings:** Go to [Charger Settings](#).
12. **Events:** View charger's events log.
13. **Edit Prices by Zone:** Set prices for defined times. See [Price Per Zone](#).

History

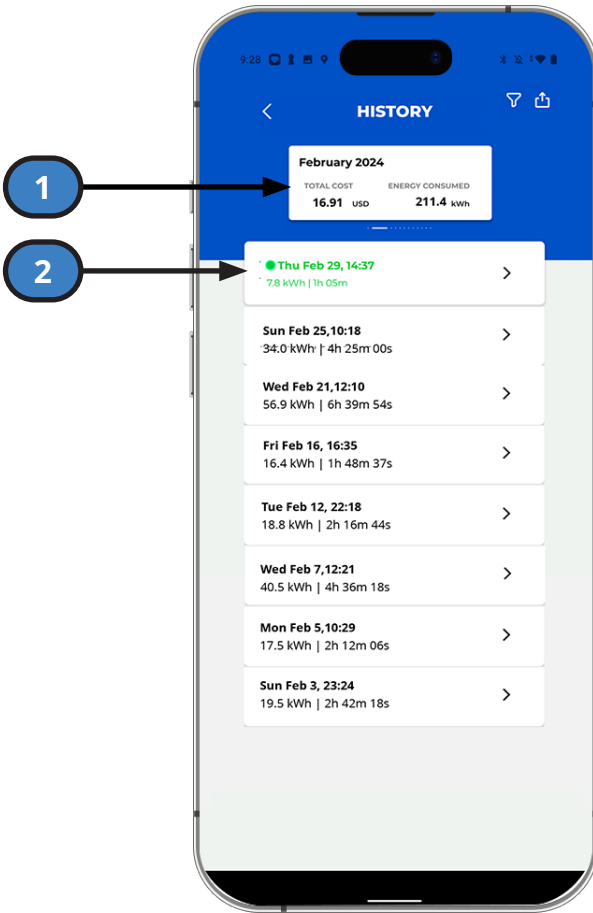

1. **Monthly Summary:** Total cost and energy consumed in the month. Swipe to see previous months.
2. **Charging Sessions:** List of previous charging session. Select charging session for detailed statistics and chart.

Schedule

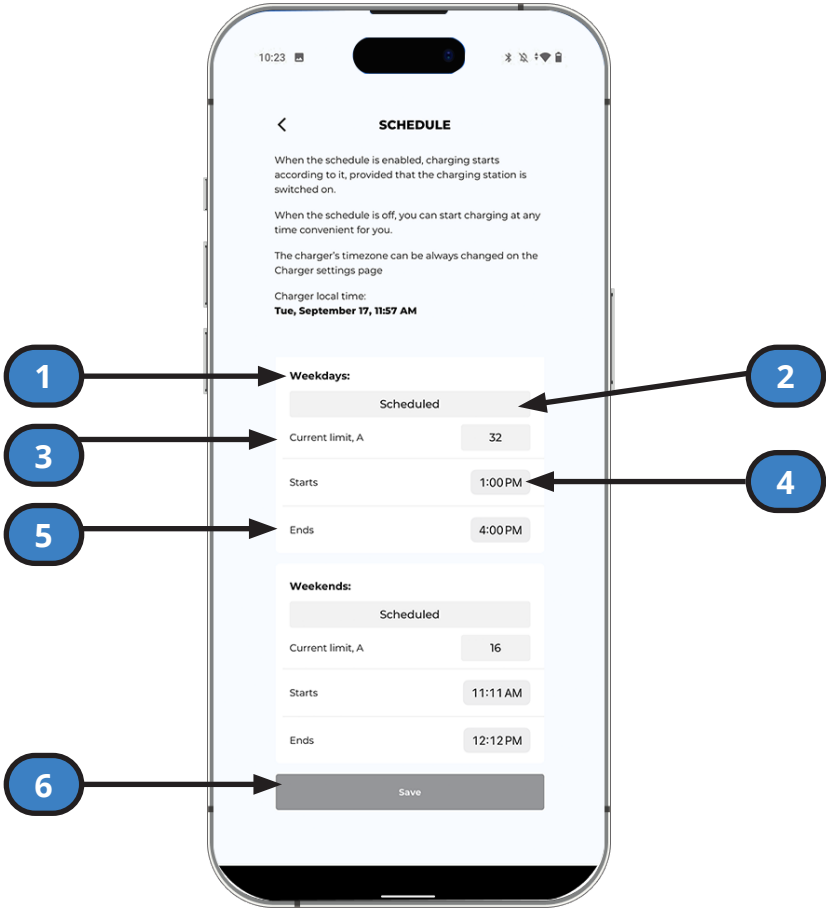

1. **Weekday/Weekend:** Set separate schedule for Monday - Friday and Saturday - Sunday.
2. **Schedule Toggle:** Select to enable schedule.
3. **Current limit, A:** Set current limit in Amps for schedule.
4. **Start Time:** Select to adjust schedule start time.
5. **End Time:** Select to adjust schedule end time.
6. **Save:** Save and apply schedule.

Charger Settings



1. **Charger Info:** Model, Manufacturer, Serial Number, Firmware Version.
2. **Time Zone:** Set Timezone Automatically or Manually for schedules and charging history. See [Time Zone](#).
3. **Share Station:** Add another user to the station. See [Share Station](#).
4. **Max Current:** Adjust the maximum current of the charger. See [Max Current](#).
5. **Firmware Update:** Displays firmware version and if new firmware is available. Select Update button to install latest firmware on charger.
6. **Charger's Name:** Give a custom name to your charger.
7. **Reboot:** Reboot the charging station.

Time Zone

The Charger uses the Time Zone to calculate schedules and price per zone.

Update the time zone to match your local time to maintain accurate information. If you move the Charger into a different time zone, update it to prevent timing errors.

Share Station

Give other users access to your station top set schedules, view history, and view events. To Share Station:

User Email:

1. Enter the User's email address into the **Email** field.
2. Have the User go their Dashboard and accept the sharing request.

QR Code

1. Display the QR Code on your device.
2. Have the User go to their Dashboard and select **Scan Invitation Code**.
3. Scan the QR Code to add charger.

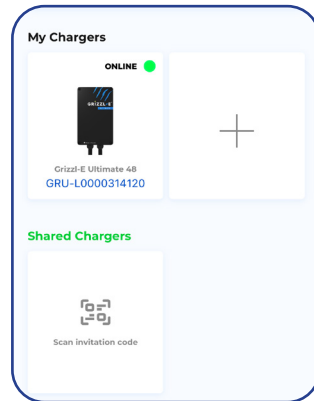
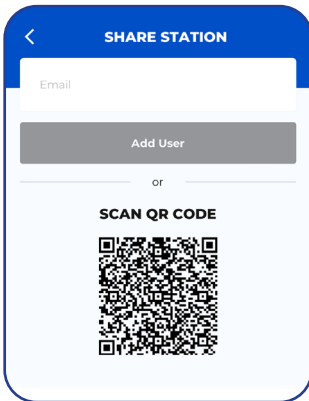

Max Current

Current can be adjusted in increments of 1A from a minimum of 7A to the maximum determined by the DIP switch settings.

Only Maximum Current settings equal to or less than the DIP switch settings will display. See [5. Maximum Current Output](#) for more information on maximum current by the DIP switches.

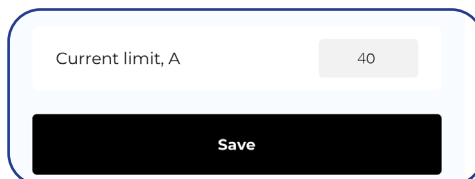

Price Per Zone

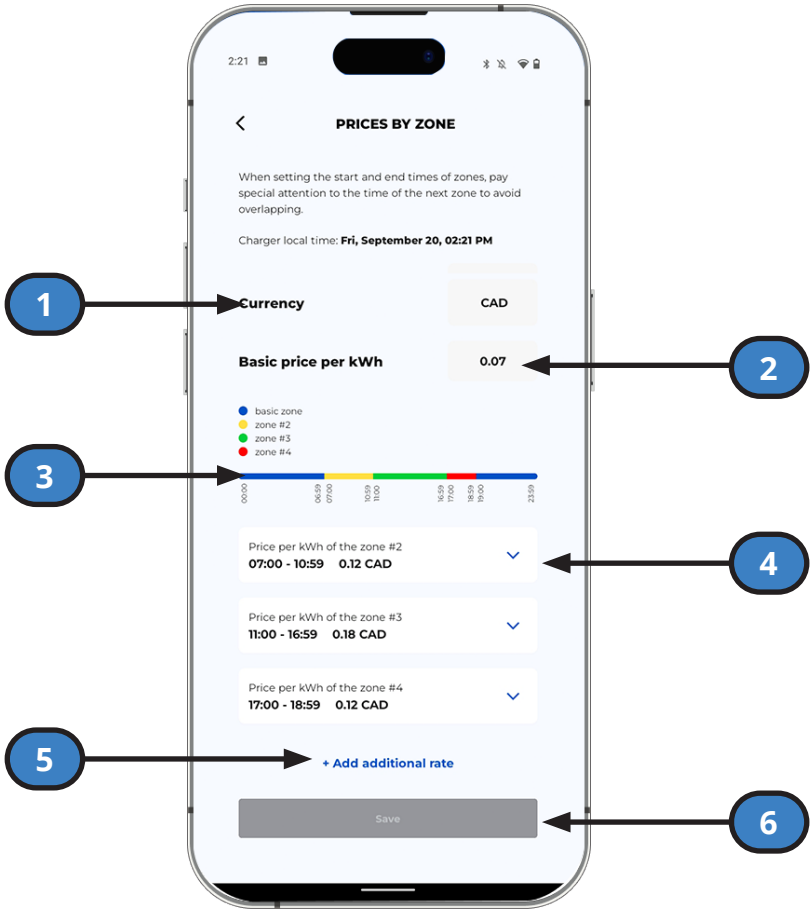

1. **Currency:** Set currency
2. **Basic price per kWh:** Default price of charging per kWh.
3. **Chart:** Shows breakdown of pricing zones over 24 hours.
4. **Rate Zones:** User defined pricing for time periods.
5. **Add additional rate:** Select to set charging prices over a time period.
6. **Save:** Save all changes before exiting.

11. LOCAL SMART FEATURES

Local Smart features are available when connected to the charger’s Wi-Fi network. Follow the instructions in this section to access and use Local Smart Features:

- Local Wi-Fi Smart features can be accessed by any device that connects to Wi-Fi (Smart Phone, Laptop, Computer).
- The user must be within range of the charger’s Wi-Fi network to access Local Smart Features.
- OCPP settings described in [10. OCPP Through Grizzl-E Connect](#) will override local smart features.

Access Local Smart Features

1. Connect to the charger’s Wi-Fi Network. The network name is the **serial number**. Stay on the network even though there is no internet connection.
2. Open your web browser. Enter the IP address **192.168.4.1** to open the local connection page. Disable cellular data if page will not load.

11.1 STATUS

Condition

Term	Definition
Status	Displays the real-time status of the charger.
Limit Status	Displays any limits on the charger.
Plugged In	Displays if the charger is plugged into the vehicle.
Voltage	The measured voltage from the charger.
Current	The measured current being delivered to the vehicle.
Power, kW	The measured power delivered to the vehicle in kW.
Relay Temperature °C	The measured temperature of the charger’s interior.
Session, kWh	The total kWh delivered to the vehicle since the start of the charging session.
Session Time	Total time of the charging session.
Session cost	The total charging session cost. Cost is calculated using the Session, kWh x the active Rate. For information on setting the rate, see Rates .
Rate	Displays the active rate used to calculate the Session Cost.
Total kWh	The total power delivered by the charger over its life.

Adjustments

Current limit, A:

Set the maximum current by using the slider:

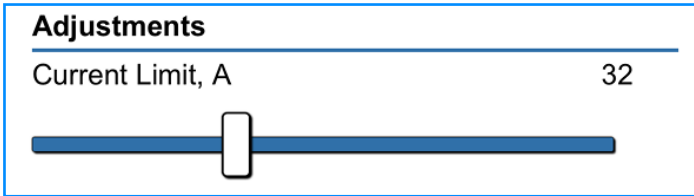

Current can be adjusted in increments of 1A from a minimum of 7A to the maximum determined by the DIP switch settings.

Only Maximum Current settings equal to or less than the DIP switch settings will display. See [5. Maximum Current Output](#) for information on how to change the Maximum Current through the DIP switches.

If the charger detects a 120V circuit, the maximum current limit will be reduced to 12A.

[Max Current](#) settings through OCPP Grizzl-E Connect will override the local Current limit. The slider will automatically adjust to match Max Current settings in the application.

Caution: Requirements govern that only 80% of the circuit-rated load may be utilized. Always ensure the set current is 80% or less of the breaker rating when using the Current Limit Slider. The charger can not detect the circuit amperage limit.

Stop Charging:

Enable the button to stop the charging session. The charger will display a yellow indicator light. Disable the button to restart the charging session.

120 V Adapter 30 A

When using the NEMA 14-50R to NEMA TT-30P adapter, enable the **120 V Adapter 30 A** button to charge at a maximum of 24A.



When enabled the **Current Limit, A** slider will have a new limit of 24A.

Counters

Two independent counters calculate the kWh and Cost of the charging:

- Select the **Reset** button beside Counter A or Counter B to reset the counter to 0.
- Counter will automatically track Energy kWh and Cost when the charging session begins.
- Use counters to track any period you wish. For example, one weekly and one monthly.

Counters	
Counter A	<input type="button" value="Reset"/>
Energy, kWh	0.0
Cost	0.0
Counter B	<input type="button" value="Reset"/>
Energy, kWh	0.0
Cost	0.0

Charts

Three Charts will show on the bottom of the Status Page:

- Voltage (V)
- Current (A)
- Temperature (°C)

Charts will update in real-time to display information from the previous 15 minutes. Charts will automatically scale to fit all data. Previous chart information is not accessible.

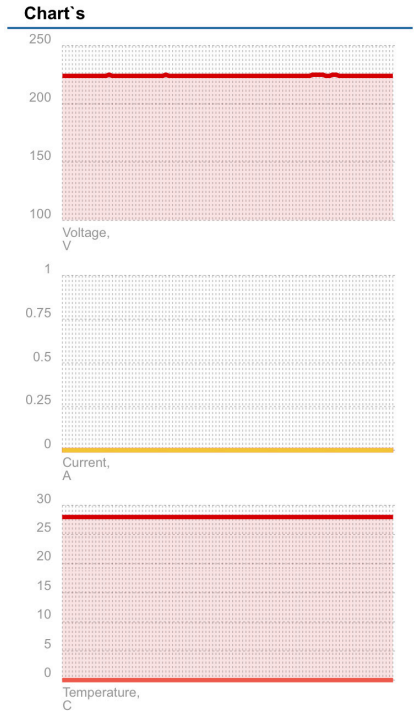

11.2 TIMER

Charge Now

Disable Limits:

Enable the **Disable Limits** button to bypass all limits and schedules and begin the charging session. All set Limitations will disable.

One charge:

Enable the **One Charge** button to bypass all limits and schedules and begin the charging session. Set Limitations will save for the next charging session. The button will automatically disable when the one charging session is complete.

Limitations

Time Limit:

The charging session will stop when the time limit has been reached. The time limit will override any set schedules.

To set the Time Limit:

1. Enable the **Time Limit** button.
2. Set the Time using the scroll bar (HH:MM:SS). The timer will begin to count down once the time limit is set.

Energy Limit kWh:

The charging session will stop once the energy limit has been reached. The Energy limit will override any set schedules.

To set Energy Limit:

1. Enable the **Energy Limit** button.
2. Set the Energy limit using the scroll bar. Energy is measured in kWh. The energy will count down once the energy limit is set.

Cost Limit

The charging session will stop when the cost limit has been reached.

To set Cost Limit:

1. Enable the **Cost Limit** button.
2. Set the Cost Limit using the scroll bar. Cost is calculated by multiplying kWh x the active rate. The cost will count down once the cost limit is set.

Rates

Set the Rates per kWh to calculate the cost of the charging session. Rates are set to \$ per kWh.

Primary Rate:

Type the primary rate into the text box.

Example: 0.12 = 12¢/kWh. This rate will apply unless Rate 2 or Rate 3 are activated.

Rate 2:

1. Enable the **Rate 2** button.
2. Set the Start and Stop time for Rate 2. Rate 2 will apply during these times.

Rate 3:

1. Enable the **Rate 3** button.
2. Set the Start and Stop time for Rate 3. Rate 3 will apply during these times.

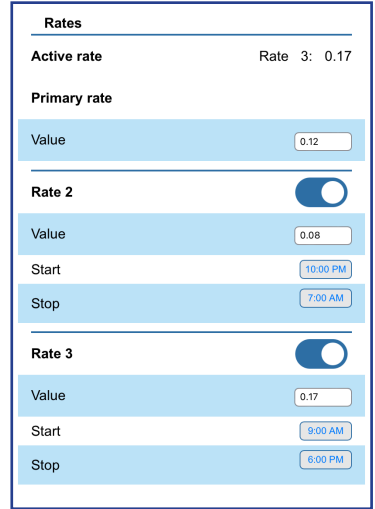

Rates

Active rate Rate 3: 0.17

Primary rate

Value 0.12

Rate 2

Value 0.08

Start 10:00 PM

Stop 7:00 AM

Rate 3

Value 0.17

Start 9:00 AM

Stop 6:00 PM

Charger Schedule

Set the charging schedule to charge at certain times.

Range 1:

1. Enable the **Range 1** button.
2. Set the Start and Stop times.

Optional: Enable **Energy Limit 1, kWh**. The power output will be limited to this value during the scheduled times.

Optional: **Enable Current limit 1, A**. The current will be limited to this value during the scheduled times.

Range 2:

Range 2 can be used alongside the Range 1. For example, use the secondary schedule for weekends or preconditioning the vehicle.

1. Enable the **Range 2** button.
2. Set the Start and Stop times.

Optional: Enable **Energy Limit 1, kWh** or **Current limit 1, A** for the secondary schedule.

If Range 1 and Range 2 schedules overlap, the schedule that begins first will apply until it reaches the stop time.

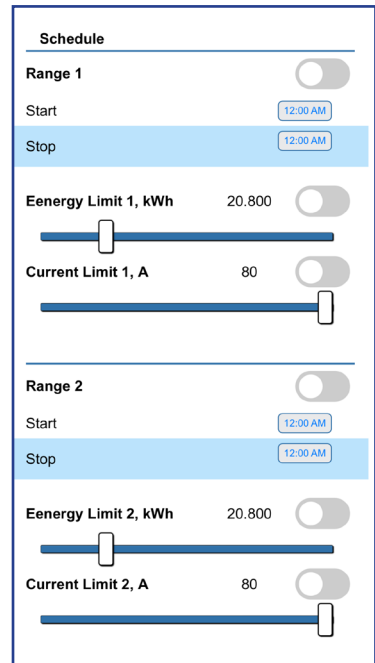

Schedule

Range 1

Start 12:00 AM

Stop 12:00 AM

Energy Limit 1, kWh 20.800

Current Limit 1, A 80

Range 2

Start 12:00 AM

Stop 12:00 AM

Energy Limit 2, kWh 20.800

Current Limit 2, A 80

System Time

Set the system Time for all schedules and rates:

1. Enter the time in the **Current Time** field.
2. Enter the **Time Zone**. Follow the chart below to enter the correct Time Zone:

Time Zone	UTC - Standard Time	UTC - Day Light Savings Time
Eastern	-5	-4
Central	-6	-5
Mountain	-7	-6
Pacific	-8	-7

3. Select the **Update Time** button. Refresh the page to apply all settings.

System time

Current time 12:07 PM

Time zone -5

Update time

Disable Limitations
and Schedule

Disable Limitations and Schedule

1. Select the **Disable Limitations and Schedule** button to reset all schedules and limitations.
2. Refresh the page to apply all settings.

11.3 SETUP

WiFi AP Configuration

Use this setting to configure the charger's Wi-Fi network.

AP Name:

Name of the Charger network. The default is the serial number. Change to any network name.

AP Password:

The password for the charger's Wi-Fi network. The default is no password. Set a password for the Charger network to prevent others from accessing the network. Confirm the password in the Confirm Password text box.

Select the **Save** button to save the AP Name and AP Password.

Note: If you forget the password see [12.3 Wi-Fi Connection Reset](#) to reset AP Name and Password to default.

Wi-Fi Connect Configuration

See [10.1 Connect to OCPP Through Grizzl-E Connect App](#) for instructions on connecting to Wi-Fi and OCPP.

Optional: Connect by MAC Address

Connect to by MAC Address if your local Wi-Fi network has multiple access points and you want to connect to the closest access point.

1. Enable the **Connect** button.
2. Enable the **Connect by Mac Address** button.
3. Select the Search button from the Available Networks section.
4. Select your network from the list of Available networks. Click directly on the network name to populate the Wi-Fi name field.

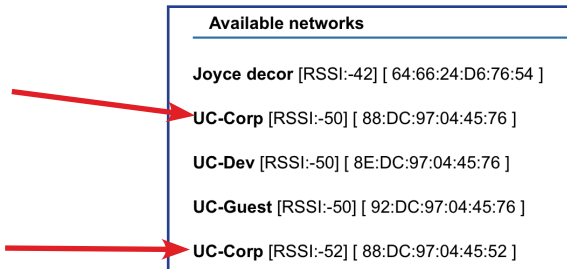

5. Select the MAC Address from the closest available access point. Multiple MAC Addresses will display if the network has more than one access point. Click directly on the MAC Address to populate the Mac of router field.

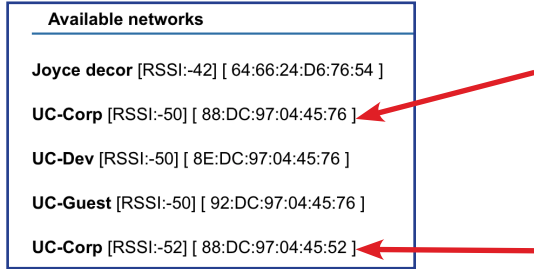

Available networks
Joyce decor [RSSI:-42] [64:66:24:D6:76:54]
UC-Corp [RSSI:-50] [88:DC:97:04:45:76]
UC-Dev [RSSI:-50] [8E:DC:97:04:45:76]
UC-Guest [RSSI:-50] [92:DC:97:04:45:76]
UC-Corp [RSSI:-52] [88:DC:97:04:45:52]

6. Select the Save button under Available Networks.
7. Enter the **Wi-Fi** Password.
8. Select the **Save** button.
9. Select the **Confirm** button to apply new settings.

Page Access

The Page Access section allows you to set a Username and Password for the web page to prevent unauthorized use.

1. Enter a Username into the **Name** field.
2. Enter a password for your page. Confirm the password in the confirm password field.
3. Select the **Save** button.
4. Refresh the web page. You will be prompted to enter the Username and Password.

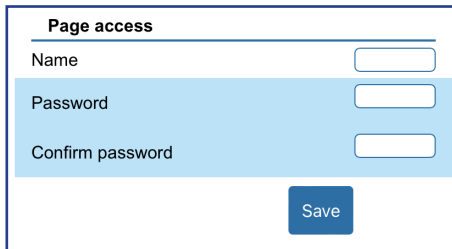

Page access	
Name	<input type="text"/>
Password	<input type="password"/>
Confirm password	<input type="password"/>
<input type="button" value="Save"/>	

Note: If you forget the password see [12.3 Wi-Fi Connection Reset](#) to reset AP Name and Password to default.

11.4 ADVANCED

Statistics

Session History displays statistics from the 4 most recent charging sessions.

Session History will display the following fields:

- Date
- Energy (kWh)
- Time
- Cost

Session history			
Date	Energy	Time	Money
24/01 12:42:42	12.6	03:09:11	2.07
23/01 15:52:59	0.0	00:16:13	0.00
23/01 15:50:41	0.0	00:01:37	0.00
23/01 14:03:22	0.0	01:28:36	0.00

Data from previous charging sessions beyond the 4 most recent is not saved.

Adaptive Mode

Adaptive Mode automatically adjusts the current to the charger if there is an unexpected drop in voltage threshold from your electric provider. It is recommended only to use Adaptive Mode if you live in an area with unstable power and frequent drops in voltage.

Contact technical support before setting it if you need clarification on whether you require Adaptive Mode.

1. Enable the **Adaptive Mode** button.
2. Set the under-voltage threshold from 180-220. Current will decrease when the voltage drops below the threshold.

Other

Timer Type

There are two different Timer Types:

- noPWM
- VW

The Timer Type is the algorithm for a delayed charge (for example, a scheduled charge). The type of algorithm used depends on the vehicle.

If a scheduled charge does not work as expected, try using a different Timer Type for better results. Contact technical support if you need clarification on whether you require Timer Type.

Minimum Voltage, V

Minimal voltage is the lowest voltage at which a charging session will proceed. The charging session will not start or will interrupt if the measured voltage is below the set minimum.

It is recommended to keep the default minimum voltage unless you live in an area with unstable power and lower voltages.

Factory Reset

Resets all settings on the charger.

12. CHARGER WI-FI FEATURES

12.1 AUTOMATIC HIDDEN WI-FI

For increased security, the Charger's Wi-Fi network [Serial Number] will display for 15 minutes after the charger is powered on. After 15 minutes, the network will be hidden.

Once hidden, the network will no longer be accessible by devices.

To restore the charger's Wi-Fi network:

1. Turn off the power to the Charging Station by switching the upstream circuit breaker to the "OFF" position or unplugging the charger.
2. Wait 1 minute. Turn on the power to the Charging Station by switching the upstream circuit breaker to the "ON" position or plugging in the charger.

12.2 DISABLE SMART FEATURES

Disabling the Smart Features will turn off any smart settings described in [10. OCPP Through Grizzl-E Connect](#) and [11. Local Smart Features](#). The charger will enter 'dumb mode' in which all charging controls are directed by the vehicle.

The Wi-Fi network and Smart Settings page will remain visible but will not control the charging station.

1. To Disable Smart Features:
2. Turn off the power to the Charging Station by unplugging or switching the upstream circuit breaker to the "OFF" position.
3. Remove the front cover by removing the 4 screws at each corner of the charging station. Use 7/64" (2.5mm) hex key to remove cover screws.
4. Place the front cover to the side. Locate the DIP switch on the charging station circuit board. The DIP switch is a 4-position switch located on the top circuit board, near the center of the charger.
5. Move the DIP Switch #1 to the **ON** position. This applies to all amperage settings.

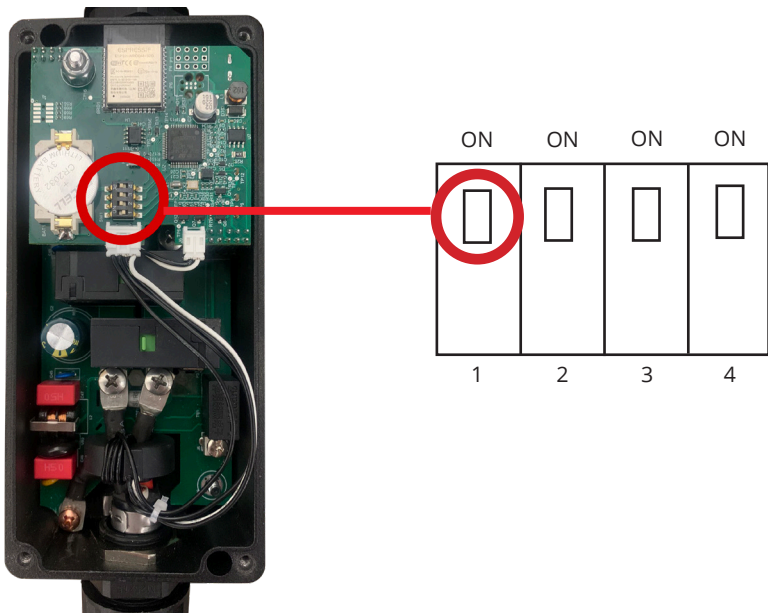

6. Reassemble the front cover.
7. Turn on the power to the Charging Station by replugging or switching the upstream circuit breaker to the "ON" position.

12.3 WI-FI CONNECTION RESET

Use the Wi-Fi Connection Reset to clear the following Wi-Fi credentials from the charger:

- The [WiFi AP Configuration](#) **AP Name** and **AP Password** will reset to the default.
- The [Wi-Fi Connect Configuration](#) **Name** and **Password** will be cleared.
- The [Page Access](#) **Name** and **Password** will be cleared.

To perform a Wi-Fi Connection Reset:

1. Turn off the power to the Charging Station by unplugging or switching the upstream circuit breaker to the “OFF” position.
2. Remove the front cover by removing the 4 screws at each corner of the charging station. Use 7/64” (2.5mm) hex key to remove cover screws.
3. Place the front cover to the side. Locate the DIP switch on the charging station circuit board. The DIP switch is a 4-position switch on the top circuit board, located on the right side of the charger.
4. Move DIP Switch #1 to the **ON** position. This applies to all amperage settings.

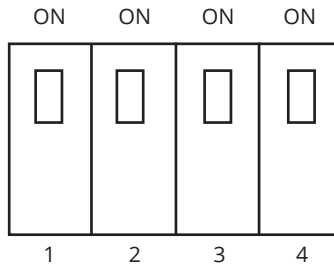

5. Restore power to the charging station by plugging in or switching the upstream circuit breaker to the “ON” position.
6. Wait 1-2 minutes, with the charger powered on.
7. Turn off the power to the Charging Station by unplugging or switching the upstream circuit breaker to the “OFF” position.
8. Return DIP Switches to the original position.
9. Reassemble the front cover.
10. Turn on the power to the Charging Station by switching the upstream circuit breaker to the “ON” position.



WARRANTY

Grizzl-E Mini Level 2 EVSE comes with either a 3-year, or 5-year manufacturer's warranty. This warranty is extended by United Chargers Inc.™ to the original purchaser of the EV Charging Station. United Chargers warrants that this product is free from defects in materials years and free from defects in workmanship for the period specified in the warranty from the date of purchase. If during the Warranty Period, under normal operating conditions, the charging station becomes defective, United Chargers will, upon written notice of the defect that occurred during the Warranty Period, provide technical support until the issue is resolved.

This warranty will not apply if the product has been misused, abused, or altered. The warranty does not cover cosmetic damage such as scratches, dents, or normal aging. The warranty does not cover damage as a result of an extreme power surge, extreme electromagnetic field, or any acts of nature. The warranty for the cable does not include normal tear and wear. This warranty does not cover plugs exposed to snow or water for an extended time. The warranty for the cable does not include cables that have been run over, pulled, or otherwise damaged by the vehicle.

A licensed contractor, licensed electrician, or trained installation expert must perform the installation or the warranty will be void.

The warranty claimant must produce the original purchase invoice, including the date of purchase. United Chargers assumes no liability for any dismantling, removal, installation, re-installation, or labor costs or any consequential damages associated with this warranty. The cumulative liability of United Chargers for warranty claims will not exceed the original price of the charging station. United Chargers shall make the final decision, in fairness to all concerned, as to the legitimacy of any such claim on this warranty.

View the full terms and conditions: <https://grizzl-e.com/returns/>

SAVE THESE INSTRUCTIONS

The most up to date User Manual is available online:

<https://grizzl-e.com/user-manuals/>

Visit our Technical Support page:

<https://autochargers.zendesk.com/hc/en-ca>

View the full terms and conditions:

<https://grizzl-e.com/returns/>

Phone: +1-833-971-8118

E-mail: rr@unitedchargers.com

Website: <https://grizzl-e.com/>

United Chargers Inc.
25 Pollard St, Richmond Hill,
ON, Canada, L4B 1A8



